

# SYNCHROTRON RADIATION: PRODUCTION & PROPERTIES



**DENNIS M. MILLS**

Deputy Associate Laboratory Director  
Advanced Photon Source

National School for Neutron and X-ray Scattering  
July 2022

# AGENDA

1. A little history lesson and anniversaries
2. Properties of radiation from relativistic electrons
3. Properties of electron beams in storage rings
4. Next generation light sources

# X-RAYS WERE A PUZZLE

- Röntgen discovery of X-rays was made by in 1895 and he first thought they might be some sort of **longitudinal vibrations of the ether**.
- These "rays" were not deflected by magnetic fields, so carried no charge, and, at the time, refraction by a prism could not be measured (we'll see why in the talk about x-ray optics).
- Others, including Charles Barkla who studied the polarization of x-rays (Nobel prize winner in 1917 for this and other work on x-ray scattering), thought they were an **extension of the visible light spectrum**.
- William Bragg was a strong proponent of x-rays being "**particles**" or **corpuscular in nature**.
- In 1896 Lord Kelvin sent G. G. Stokes a letter ending thus: "*In respect of the Rontgen X-rays, are you a longitudinalist, or an ultravioletist, or a tertium quidist?*"
- The discussions must have been lively in the early 1900's, as in his 1927 Nobel acceptance speech, Compton calls out that: "***Many will recall also the heated debate between Barkla and Bragg, as late as 1910, one defending the idea that X-rays are waves like light, the other that they consist of streams of little bullets....***".

Wilhelm Röntgen  
1845 – 1923



Charles Barkla  
1877 – 1944



William Bragg  
1862 – 1942

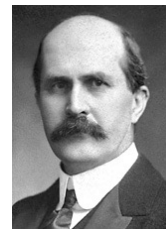

G. G. Stokes  
1819 – 1903



Lord Kelvin  
1824 – 1907

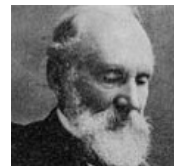

# 100<sup>TH</sup> ANNIVERSARY OF THE DISCOVERY OF THE COMPTON EFFECT

1927 Nobel Prize citation for Compton:

*According to Einstein's photoelectric effect theory, light consists of quanta, "packages" with definite energies corresponding to certain frequencies. A light quantum is called a photon. When Arthur Compton directed X-ray photons onto a metal surface in 1922, electrons were emancipated and the X-rays' wavelength increased because some of the incident photon energy was transferred to the electrons. The experiment confirmed that electromagnetic radiation could also be described as photon particles following the laws of mechanics.*

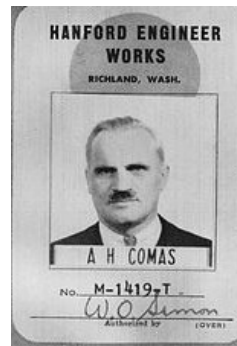
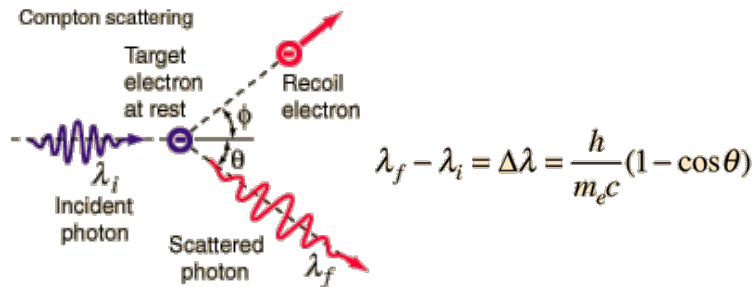

Arthur Compton's ID badge from the Hanford Site. For security reasons he used a pseudonym.

**Arthur Holly Compton**  
Born: September 10, 1892  
Died: March 15, 1962

- Moved to the University of Chicago from Washington University in 1923.
- Awarded Nobel prize in 1927.
- In April 1941, the National Defense Research Committee created a special project headed by Compton to look into a uranium-based weapon.
- Compton decided to build Chicago Pile-1, the first nuclear reactor, under the stands at Stagg Field. Under Fermi's direction, it went critical on December 2, 1942.
- Compton was placed in charge of the Manhattan Project's plutonium production at Hanford, Washington.
- In 1946 he returned to Washington University as the Chancellor.
- The APS Compton Award, given to recognize an important scientific or technical accomplishment at the APS, was named Compton.

# 75<sup>TH</sup> ANNIVERSARY OF THE DISCOVERY OF SYNCHROTRON RADIATION

Synchrotron Radiation (SR) - radiation from charged particles traveling in circular orbits - was first observed from a 70 MeV synchrotron at GE in Schenectady in 1947.

*On April 24, [1947] Langmuir and I [Herbert Pollack] were running the machine... Some intermittent sparking had occurred and we asked the technician to observe with a mirror around the protective concrete wall. He immediately signaled to turn off the synchrotron as "he saw an arc in the tube." The vacuum was still excellent, so Langmuir and I came to the end of the wall and observed. At first we thought it might be due to Cerenkov radiation, but it soon became clearer that we were seeing Ivanenko and Pomeranchuk [i.e., synchrotron] radiation.*

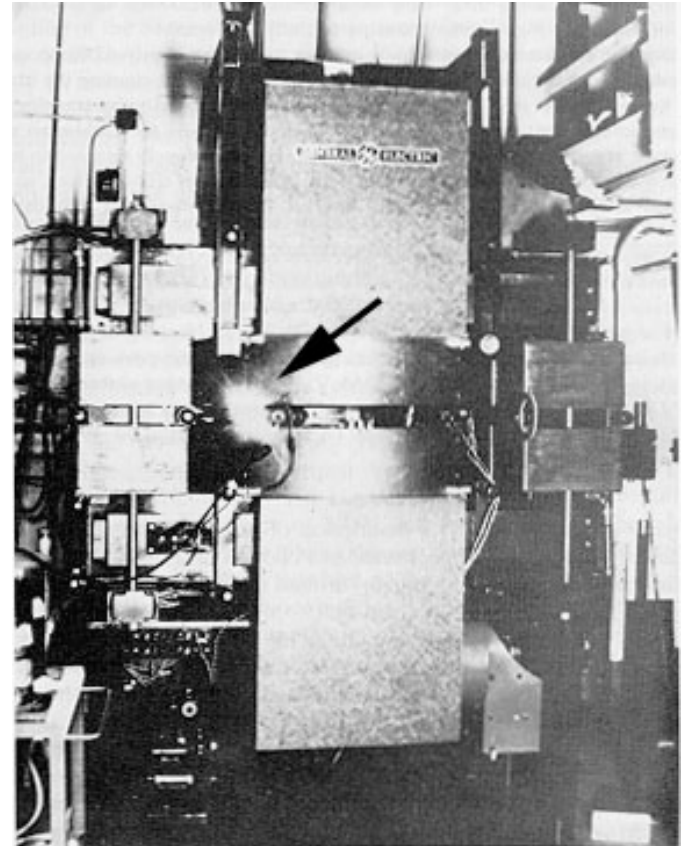

Excerpted from Handbook on Synchrotron Radiation,  
Volume 1a, Ernst-Eckhard Koch, Ed., North Holland, 1983.

# FROM SYNCHROTRONS TO STORAGE RINGS

- Synchrotrons were first used as sources of SR. However, the particles' constantly changing energy was not attractive and the advent of storage rings provided a far more attractive source.
- We now use the name synchrotron radiation to describe radiation that is emitted from charged particles traveling at relativistic speeds, regardless of the accelerating mechanism and shape of the trajectory.

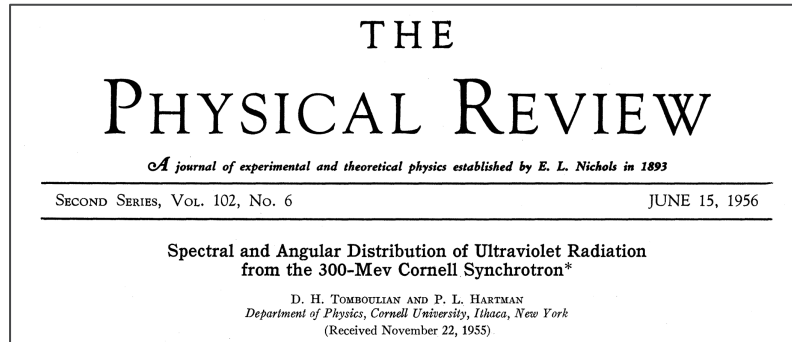

For more info on the early users of synchrotron radiation see:  
Synchrotron Radiation News, Volume 28, Issue 4 (2015)  
Special Issue on Pioneers in Synchrotron Radiation

## Letters to the Editor

*Prompt publication of brief reports of NEW ideas in measurement and instrumentation or comments on papers appearing in this Journal may be secured by addressing them to this department. No proof will be sent to the authors. Communications should not exceed 500 words in length. The Board of Editors does not hold itself responsible for the opinions expressed by the correspondents.*

### Use of Synchrotron Orbit-Radiation in X-Ray Physics\*

L. G. PARRATT

*Cornell University, Ithaca, New York*

(Received December 1, 1958)

IT is well known by now that intense x-radiation is emitted by the centripetally accelerated electrons in the orbit of a high-energy synchrotron.<sup>1</sup> Comparison is made here of the prospective usefulness of this radiation in the range of wavelengths 0.1 to 20 Å with the x-rays obtainable from a conventional x-ray tube.

I. Calculations of the spectral distribution for three typical synchrotron energies and orbit radii are shown in Fig. 1.<sup>2,3</sup> The spectral power is shown averaged over one-half of an acceleration cycle in which the electron energy is taken as proportional to the square of a sinusoid.<sup>4</sup> The power is expressed in ergs per second per  $4\pi$  solid angle per  $x$  unit per electron, and must be trimmed

# PROPERTIES OF THE X-RAYS

# RADIATION PATTERNS FROM ACCELERATING CHARGES

## Definitions:

$$\beta = v/c$$

$$\gamma = 1/\sqrt{1-\beta^2} = E/m_0c^2$$

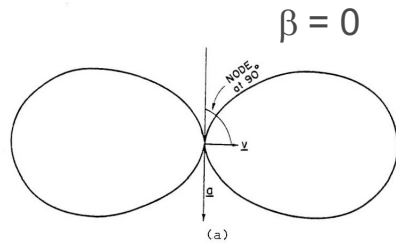

These are standard polar plots where  $\Psi$  is the angular coordinate

- When  $v \ll c$ , ( $\beta \approx 0$ ), the shape of the radiation pattern is a classical dipole pattern.
- But as  $\beta$  increases, the shape of the radiation pattern changes; it is more forward directed

Lorentz transformation

$$\tan(\psi)_{lab} = \frac{\sin \psi'}{\gamma(\cos \psi' + \beta)} = \frac{1}{\gamma\beta} \approx \frac{1}{\gamma}$$

When  $\Psi$  is small,  
 $\tan(\Psi) \approx \Psi$  so  $\Psi \approx 1/\gamma$ .

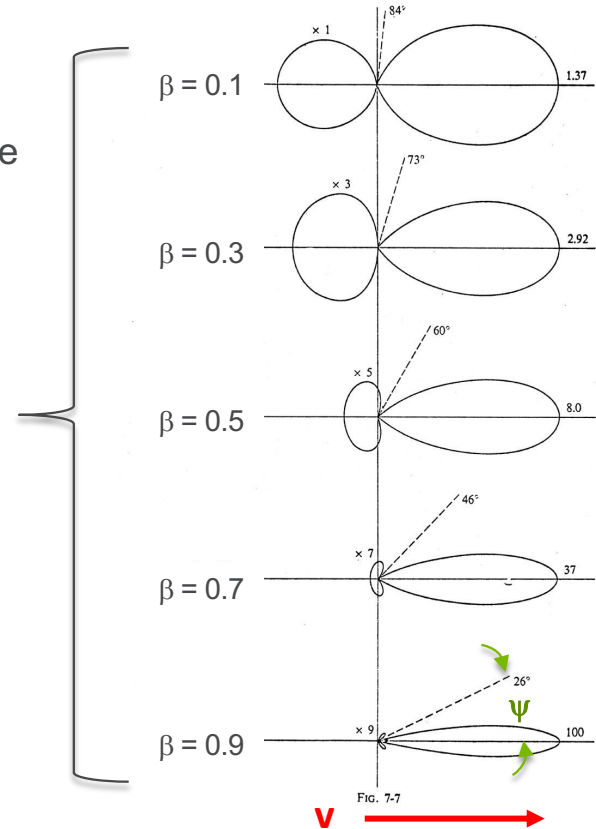

$V$  is instantaneous velocity vector

The angular spread of the forward emitted radiation (sometimes called the opening angle), is approximately  $1/\gamma$ .



# RADIATION FROM HIGHLY RELATIVISTIC ( $\gamma \gg 1$ ) PARTICLES IN A CIRCULAR ORBIT

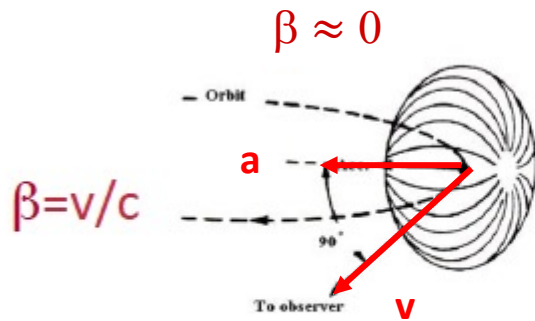

$v$  is the velocity vector  
 $a$  is the acceleration vector

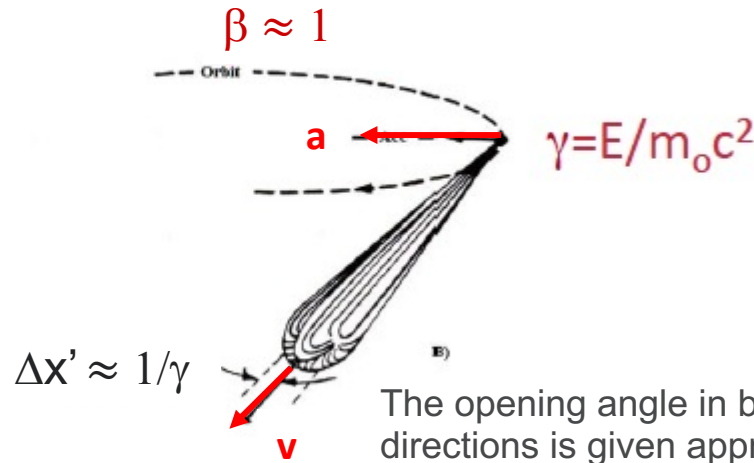

The opening angle in both the horizontal and vertical directions is given approximately by:

$$\Delta x'_{\text{rad}} = \Delta y'_{\text{rad}} \approx 1/\gamma, \text{ when } \beta \approx 1.$$

$$\text{@ APS } \beta \approx 1 - (2 \times 10^{-9})$$

Relativistic velocities are good!!

- radiation forward directed
- radiated power  $\propto E^4$

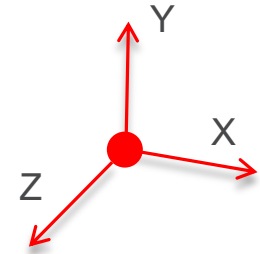

Primes denote angles  
 $x'$  ( $y'$ ) is the angle from the velocity vector,  $V$ , in the  $x$ - ( $y$ ) plane

At the APS with  $E = 7 \text{ GeV}$ ,  
 $\gamma = E/m_0c^2 = 7 \text{ GeV}/0.511 \text{ MeV}$   
 $\gamma = 1.4 \times 10^4$   
 $1/\gamma = 73 \times 10^{-6}$

See Appendix 1 for more details

# ANATOMY OF SYNCHROTRON RADIATION FACILITY

## ADVANCED PHOTON SOURCE

### BEAM ACCELERATION & STORAGE SYSTEM

(A) ELECTRON GUN

(B) ELECTRON LINEAR ACCELERATOR

Output energy: **375 MeV**

(C) PARTICLE ACCUMULATOR RING

(D) BOOSTER SYNCHROTRON

Nominal extraction energy: **7.0 GeV**

(E) STORAGE RING

Nominal energy: **7.0 GeV**

(E1) INSERTION DEVICE

(E2) BENDING MAGNET

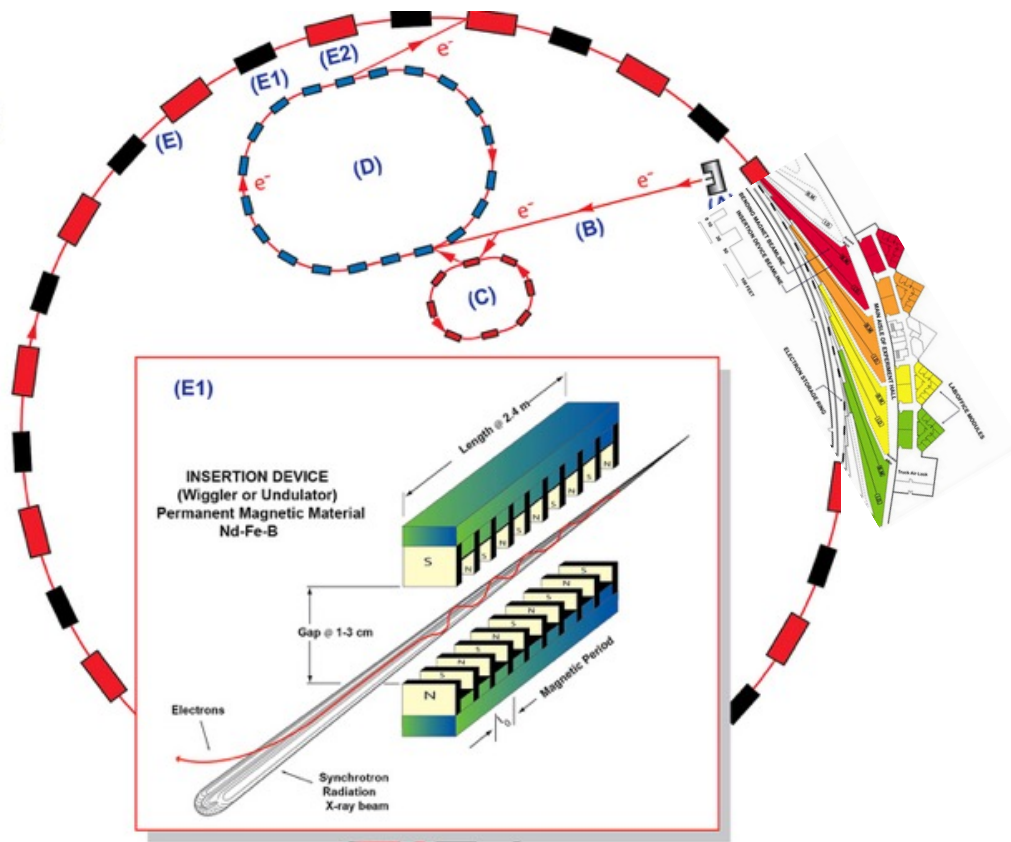

NOTE: Diagrams not to scale

# BEND MAGNET (BM) X-RAY RADIATION PROPERTIES

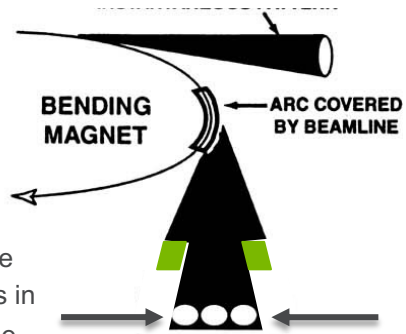

Horizontal opening angle determined by apertures in the front-end or beamline.

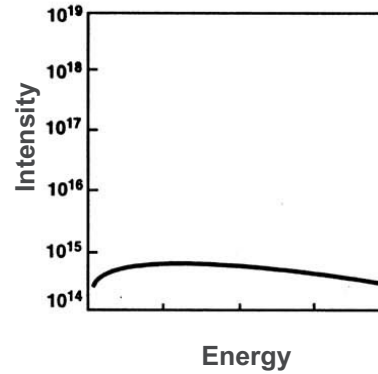

You get this for “free” since you need the bending magnets to keep the electrons orbiting in the storage ring.



## Bend Magnet Radiation

Spectrum characterized by the critical energy:

$$E_c[\text{keV}] = 0.066 B[\text{kG}] E^2 [\text{GeV}] \quad (E_c \approx 20 \text{ keV @ APS})$$

$$\text{Recall: } \lambda[\text{\AA}] = 12.4/E[\text{keV}] \quad \text{so } 20 \text{ keV is } 0.62\text{\AA}$$

All the BMs have the same B-field to maintain a closed orbit, so spectrum from each BM is the same.



Vertical opening angle ( $\Delta y'$ ) is  $1/\gamma$ . At the APS:

$$\gamma = 1.4 \times 10^4$$

$$\text{so } 1/\gamma = 73 \times 10^{-6} \text{ radians}$$

See Appendix 2 for more details

# PLANAR INSERTION DEVICES (IDs)

IDs are “inserted” in straight sections of the storage ring between bend magnets.

- Insertion devices (IDs) are periodic magnetic arrays with alternating field directions that force the particles to oscillate as they pass through the device.
- “Planar” refers to the magnetic field being in one direction (in this case vertical or y-direction).
- IDs can have fields in both the vertical and horizontal directions to produce circularly polarized x-rays and for other applications.

## INSERTION DEVICE (WIGGLER OR UNDULATOR) PERMANENT MAGNETIC MATERIAL Nd-Fe-B

The strength of the magnetic field,  $B$ , is varied by changing the gap between the permanent magnets in the upper and lower halves of the insertion device.

Beam of electrons continues around the ring being bent by the bending magnets (not shown for clarity).

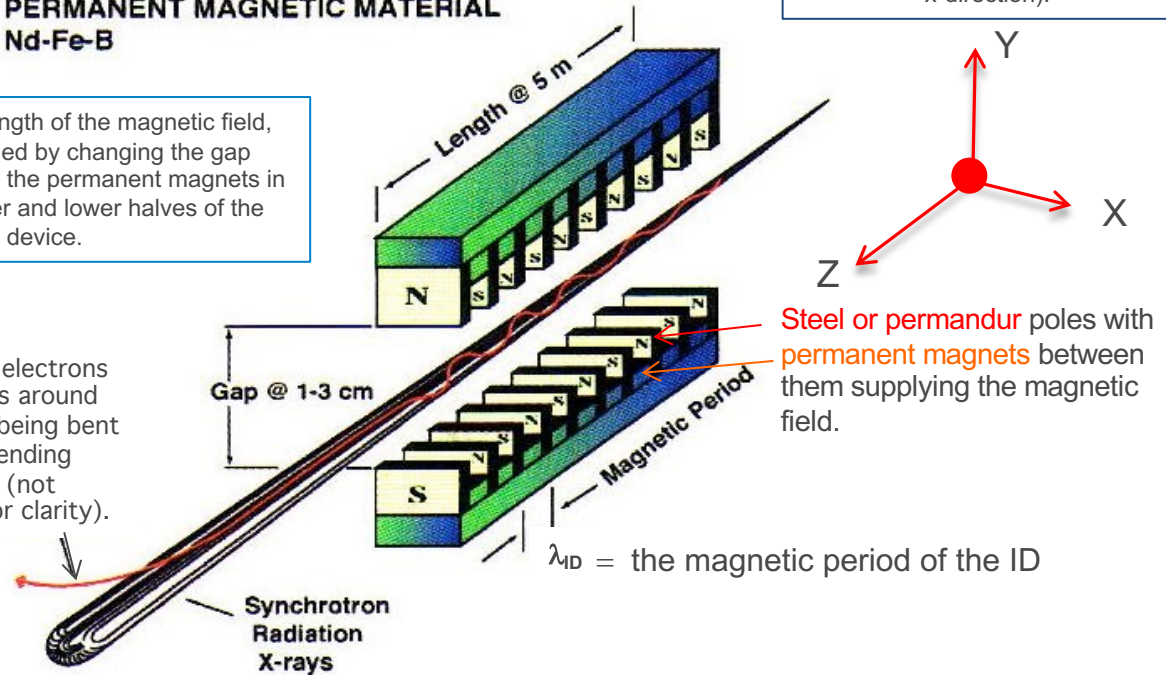

# CHARACTERIZING INSERTION DEVICES

- IDs are characterized by the so-called field index or deflection parameter,  $K$

$$K = eB_0\lambda_{ID}/2\pi m_0c = 0.0934 \lambda_{ID}[\text{cm}] B_0[\text{kG}]$$



Important thing here is  $K$  is proportional to mag field,  $B$ .

where  $\lambda_{ID}$  is the magnetic period of the insertion device and  $B_0$  the peak magnetic field. The length of the insertion device,  $L$ , is equal to the number of periods,  $N$ , times the length of the period, i.e.,

$$L = N\lambda_{ID} .$$

- The maximum deflection angle of the particle beam,  $x'_{ID,max}$ , is given by:

$$x'_{ID,max} = \pm(K/\gamma)$$



APS Undulator A has a period of 3.3 cm and operates with  $K \approx 1$ , therefore:

$$x'_{ID,max} \approx 1/\gamma$$

See Appendix 3 for more details on  $K$

# WIGGLER ( $K \gg 1$ )

Horizontal deflection angle of electrons given by  $x'_{ID, \max} = (K/\gamma)$

Radiation spectrum looks like 2N dipole sources  
(N = number of periods)

$$x'_{ID, \max} = (K/\gamma) \gg 1/\gamma$$

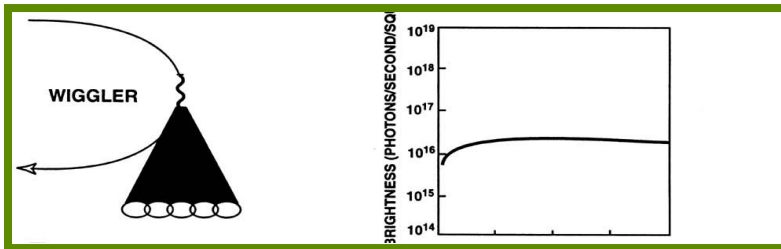
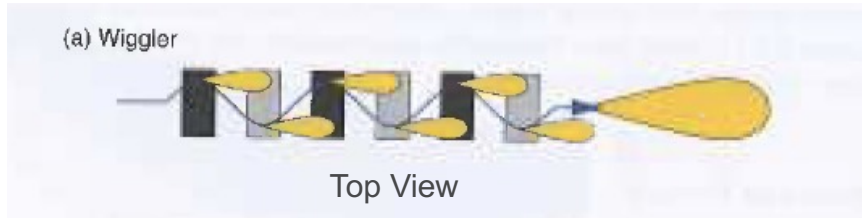

# UNDULATOR ( $K \approx 1$ )

When the maximum deflection of the electron beam is on the order of the natural opening angle of the emitted radiation, i.e.

$$x'_{ID, \max} = (K/\gamma) \approx 1/\gamma,$$

radiation from each of the magnetic pole overlaps.

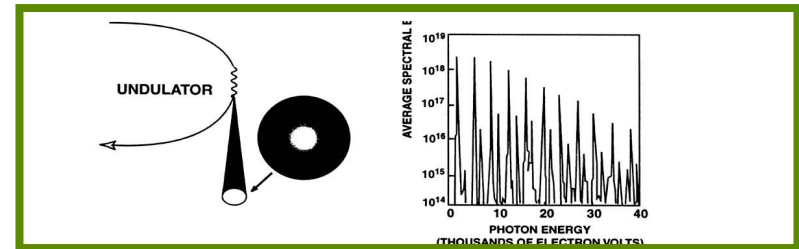
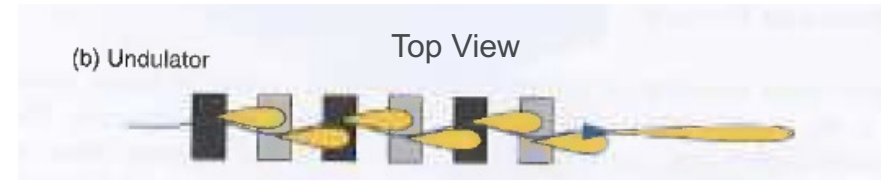

# UNDULATOR RADIATION SPECTRA – IT'S COMPLICATED

- This overlap can cause interference effects in the spectrum.
- On-axis ( $x' = y' = 0$ ), the constructive interference occurs at a particular x-ray energy ( $E_n^{x\text{-ray}}$ ) and its odd harmonics, i.e.  $n = 1, 3, 5, \dots$  when:

$$E_n^{x\text{-ray}} = [nhc \gamma^2] / [\pi \lambda_{ID}(1 + K^2/2)]$$

$h$ =Planck's constant and  $c$  the velocity of light.

- Recall that  $K$  is proportional to the peak magnetic field generated by the undulator.
  - In permanent magnet undulators vary the gap between the upper and lower poles to change magnetic field
  - In a superconductor undulator, vary the current in the windings to change magnetic field
- At the fundamental (1<sup>st</sup> harmonic or  $n = 1$ ), the horizontal and vertical opening angles of the radiation is given by:

$$\Delta x'_{\text{rad}} = \Delta y'_{\text{rad}} \approx (1/\gamma) [1/N]^{1/2}$$

where  $N$  = number of periods [typically 100 or so].

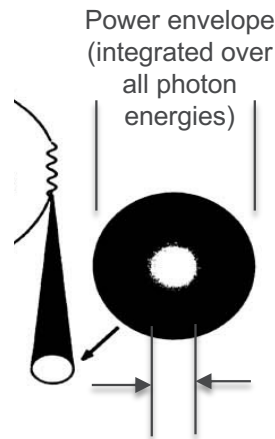

$$\Delta x'_{\text{rad}} = (1/\gamma) [1/N]^{1/2}$$

I've labeled the x-ray radiation properties with the subscript "rad" to distinguish it from the electron beam source size and divergence that will be discussed later.

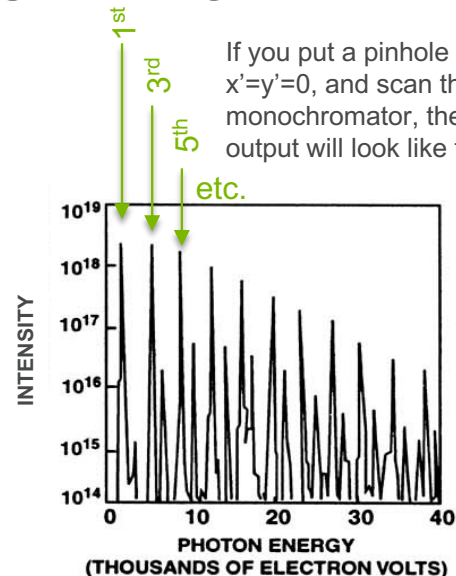

If you put a pinhole at  $x'=y'=0$ , and scan the monochromator, the output will look like this.



This narrowing of the radiation beam's divergence only occurs at energies,  $E_n^{x\text{-ray}}$ . This low divergence cone, embedded in the larger power envelope, is sometimes called the central cone of the undulator beam.

# THE DIFFRACTION LIMIT FOR LIGHT

- Just as the Uncertainty Principle sets a lower limit for the product of the size,  $\Delta x$ , and momentum  $\Delta p_x$ , this relationship can be re-written in terms of size  $\Delta x_{\text{rad}}$  ( $\Delta y_{\text{rad}}$ ) and angular divergence  $\Delta x'_{\text{rad}}$  ( $\Delta y'_{\text{rad}}$ ) for radiation.

$$\Delta x \Delta p_x \geq h / 4\pi \longrightarrow \Delta x_{\text{rad}} \Delta x'_{\text{rad}} \geq \lambda / 4\pi \quad \text{and} \quad \Delta y_{\text{rad}} \Delta y'_{\text{rad}} \geq \lambda / 4\pi$$

See Appendix 4  
for details

- A light beam that satisfies  $\Delta x_{\text{rad}} \Delta x'_{\text{rad}} = \lambda / 4\pi$  is called **diffraction limited**. When a radiation beam has this property, it is a **fully coherent source**.
- Another way to define a **diffraction limited beam** is if its potential to be focused to small spots is as high as possible for its wavelength.
- The diffraction limit at 1 Å is:

$$\lambda / 4\pi = 1\text{Å} / 4\pi = 10^{-10} \text{ meters} / 4\pi \approx 8 \times 10^{-12} \text{ m or}$$

**8 picometers-radian** (radians are dimensionless)

APS Undulator A has a length of 2.4 meters. For 1 Å radiation the natural opening angle is:

$$\Delta x'_{\text{rad}} = 1/\gamma (1/N)^{1/2} = 4.5 \times 10^{-6} \text{ rad}$$

where N = number of magnetic periods in the undulator.

The corresponding size is:

$$\Delta x_{\text{rad}} = [\lambda\gamma/4\pi][N]^{1/2} = 1.7 \times 10^{-6} \text{ m}$$

I've labeled the x-ray properties with the subscript "rad" to distinguish it from the particle beam source size and divergence that will be discussed in the second half of the talk.



# ELECTRON BEAM PROPERTIES ARE KEY

- So far, this discussion has not taken into account the properties of the source of the x-rays – namely the electron beam.
- The electron beam has both a size and divergence in the x- and y-directions (transverse to the velocity of the beam).
- The electron beam also has a finite length in the z-direction (along the direction of the velocity of the beam – sometimes called the longitudinal properties).
- To fully understand the properties of the emitted x-ray beams, we need to look a little more closely at the (transverse) properties of the electron beams.
- But first, let's look at the longitudinal properties.

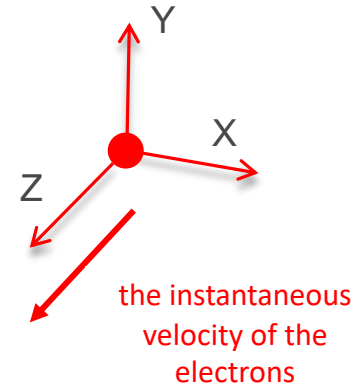

# PROPERTIES OF THE ELECTRON BEAM: TRANSVERSE AND LONGITUDINAL

# LONGITUDINAL PROPERTIES - PULSE DURATION

- Because the electrons are radiating x-rays, they are constantly losing energy, and so to restore the energy loss on each revolution, radio-frequency (RF) resonant cavities are installed in the storage ring to replenish the radiative energy losses.
- Particles are grouped together by the action of the radio-frequency (RF) cavities into bunches. At APS:
  - 1104 m circumference (3.68 microsecond period)
  - there are 1296 evenly spaced “RF buckets” (stable orbit positions) around the ring
  - the bunch length of the electron packet in one of these “buckets” is about 3 cm in length, corresponding to a **pulse duration** of about 100 psec

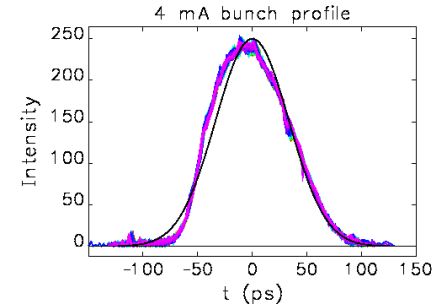

electron packet in the storage ring

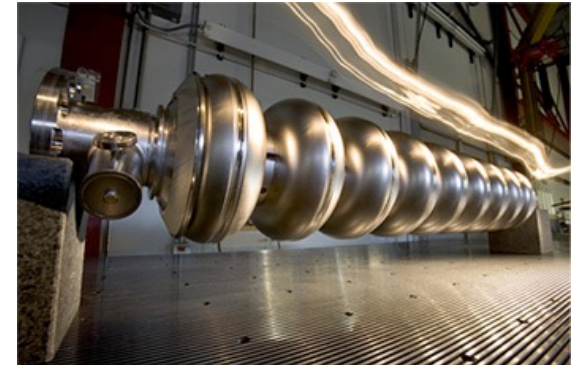
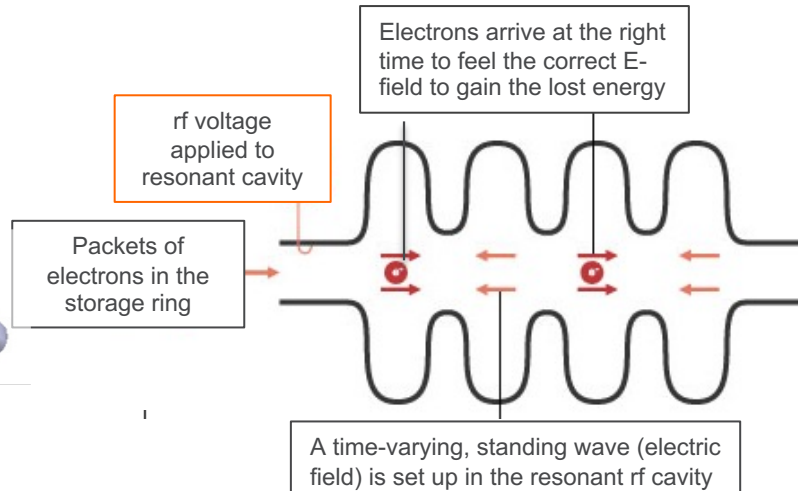
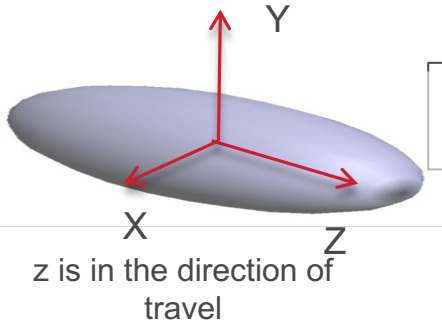

# APS TIME STRUCTURE DEPENDS ON FILL PATTERNS (100 mA TOTAL CURRENT)

## Fill patterns

**24-bunch (65%):** 80 ps (FWHM), 4.25 mA



**Hybrid-singlet (15%):** 120 ps (FWHM), 16 mA



**324-bunch (20%):** 50 ps (FWHM), 0.3 mA



- The time structure is determined by which of the rf buckets are filled with electrons.

## 24 equally spaced bunches (about 4 mA/bunch)

- compromise between quasi-continuous source and pulsed source

## 1 + 8x7 (12-14 mA in one bunch and the rest of the 100 mA distributed in 7 trains of 8 closely spaced bunches on the other side of the ring)

- timing experiments

## 324 equally spaced bunches (about 0.3 mA/bunch)

- approximates a quasi-continuous source

# TRANSVERSE (X & Y) ELECTRON BEAM PROPERTIES

- Although the flux from undulators can be determined without knowledge of the source size and divergence, one very important characteristic of the x-ray beam, namely **brightness**, requires a more detailed knowledge of the particle beam's size and divergence.

**Brightness** has units of: photons/sec/0.1% BW/source area / source divergence

$$\text{Flux} / 4\pi^2 \Sigma_x \Sigma_y \Sigma_x' \Sigma_y'$$

this is the monochromaticity of the beam

where  $\Sigma_i$  ( $\Sigma_i'$ ) is the **effective** one sigma value of the source size (divergence) in the  $i^{\text{th}}$  direction. The total source size and divergence is the quadrature sum of the electron beam and the radiation beam, namely:

We previously determined  $\Delta x_{\text{rad}}$  and  $\Delta x'_{\text{rad}}$  for undulator radiation

$$\Sigma_x = [\Delta x_{\text{rad}}^2 + \Delta x_{\text{electron}}^2]^{1/2}$$

radiation beam size

electron beam size

and

$$\Sigma_x' = [\Delta x'_{\text{rad}}^2 + \Delta x'_{\text{electron}}^2]^{1/2}$$

radiation beam divergence

electron beam divergence

and a similar expression for  $\Sigma_y$

and a similar expression for  $\Sigma_y'$

# TRANSVERSE PROPERTIES OF PARTICLE BEAMS

- When a bunch of electrons are injected into a storage ring, the ensemble of electrons rattles around until it reached its equilibrium values, in both the transverse (x and y directions) and longitudinal (z) directions.
- Here we are interested in the **transverse** (x and y) properties.
- Accelerator physicists describe the electron beam in terms of its horizontal (x-plane) and vertical (y-plane) position and divergence or its **phase space**.
- This definition of **phase space** has as the two conjugate variables

$x$  and  $x'$  (or,  $y$  and  $y'$  ).

- The area bounded by an ellipse that captures some given fraction of electrons in this  $xx'$  ( $yy'$ ) phase space is proportional to what is called the **horizontal (or vertical) emittance** of the electron beam.

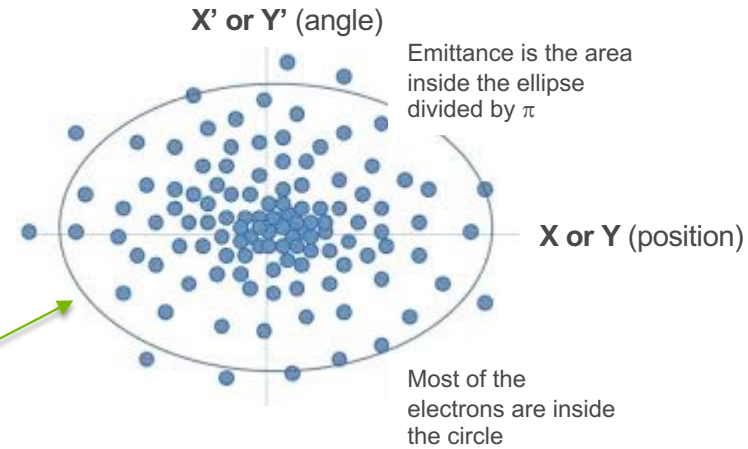
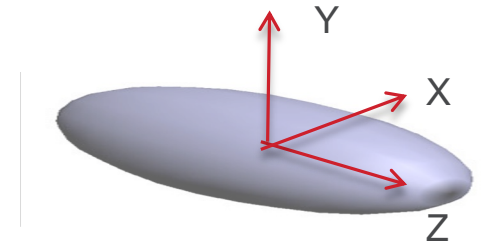

Remember: this plot is not the beam cross-section, but a phase space representation!!!

# ELECTRON BEAM PHASE SPACE AND EMITTANCE

- There is a separate horizontal emittance ( $\epsilon_x$ ) and vertical emittance ( $\epsilon_y$ ). In today's storage rings:

$\epsilon_y$  is typically 1% to 10% of  $\epsilon_x$  (the percentage is called the coupling)

- The **emittance is a constant of the storage ring**, although one can trade off electron beam size for divergence as long as the area of the phase-space remains constant.
- To determine the x-ray beam brightness, you need to know the electron beam source size and divergence at the spot in the storage ring where the undulator is located and add those values - in quadrature - with source size and divergence of the radiation.

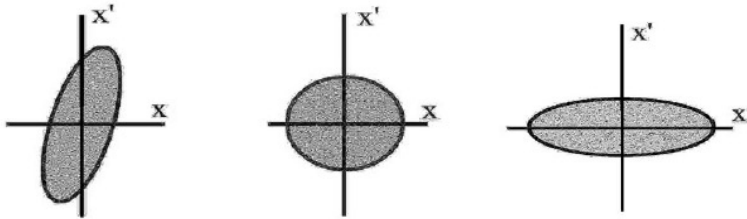

This is a consequence of Liouville's Theorem – the conditions for which are satisfied in most accelerators.

Source Point Data Generated Mon Jul 11 15:49:44 CDT  
2022 for I=75.75 mA

Name	Cplng	Sx	Sxp	Sy	Syp	ex
	%	um	urad	um	urad	nm
S1ID	0.9	308.8	13.7	9.6	4.1	3.33
S2ID	0.9	309.9	13.8	9.6	4	3.35

$$\epsilon_x \approx 3 \times 10^{-9} \text{ m-rad or } 3000 \text{ pm-rad}$$

$$\epsilon_y \approx 0.03 \times 10^{-9} \text{ m-rad or } 30 \text{ pm-rad}$$

# DIFFRACTION LIMITED SOURCES AND COHERENCE

- If both the horizontal and vertical emittance of the particle beam were small compared to the diffraction limit of the light ( $\lambda / 4\pi$ ), then the x-rays that are emitted would **have full transverse coherence**.
- But at the APS, as with most 3<sup>rd</sup> generation synchrotron radiation sources, the electron beam emittance dominates - see figure below.
- Hence the radiation is **partially coherent**
- Partially coherent sources are characterized by the **coherent fraction**, the fraction of the x-ray flux that is coherent.
- Coherent fraction = ratio of diffraction-limited emittance to actual beam emittance.
- For the APS at 1Å, the coherent fraction is  $\approx 10^{-3}$  – useful for experiments that rely on coherence but at the expense of throwing away a lot of (incoherent) flux.

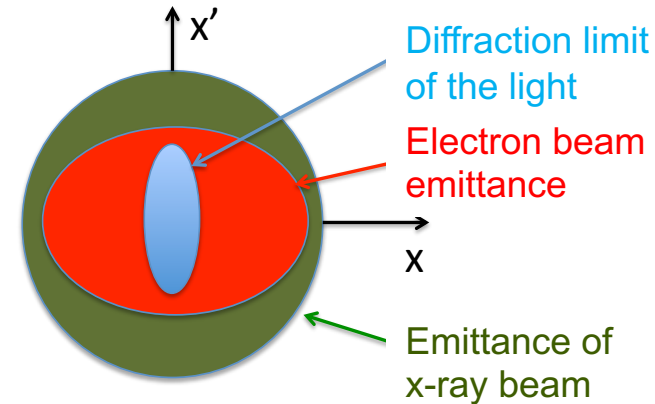



# NEXT GENERATION LIGHT SOURCES

# THE EVOLUTION OF X-RAY BRIGHTNESS FROM STORAGE RING SOURCES

- 1st Generation Sources
  - *Ran parasitically on accelerations for high- energy physics (CHESS and SSRL originally)*
- 2nd Generation Sources
  - *Built to optimize synchrotron radiation from the bending magnets (NSLS)*
- 3rd Generation Sources
  - *Built to optimize synchrotron radiation from insertion devices (ALS, APS, NSLS II)*
- 3.5 (?) Generation Sources
  - *Based on multi-bend achromat (MBA) storage ring lattices to go towards a diffraction-limited source (ALS-U, APS-U) (more later)*
- 4th Generation Sources
  - *fully coherent sources*
    - *X-ray Free Electron Lasers - X-FELs (LCLS)*
    - *Diffraction Limited Storage Rings (DLSRs)*

See presentation by P. Fouss for details on FELs

History of (8-keV) X-Ray Sources

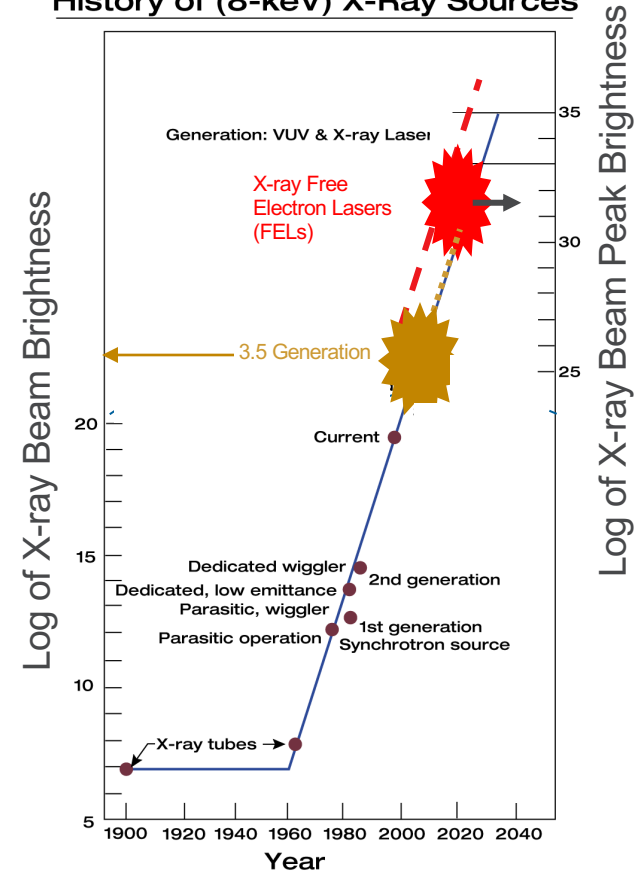

# THE DRIVE FOR MORE COHERENT SOURCES

- How do we get from where we are today ( $\varepsilon_x = 3000$  picometer-radian) to something closer to the 8 picometers-radian emittance for a fully coherent beam at  $1\text{\AA}$ ?
- Presently there are two approaches to obtain a more coherent x-ray source:
  - Storage rings with so-called Multi-bend Achromat (MBA) magnet structures
  - Using LINACs that satisfy the conditions for a free electron laser (FEL) - – *See Appendix 6*

The accelerator physics for both these approaches has been known and understood for sometime – **WHY NOW???**

In my humble opinion, it has been advances in **modeling/simulations** along with the availability of **high performance computing** that gave designers and builders (and funders) the confidence that these machines could be successfully built.

Weiderman, *Design of low emittance storage rings*, NIM 246, 15 May 1986.

Pellegrini, C. *SASE and Development of an X-Ray FEL*. Proc. of the Workshop for Prospects for a  $1\text{\AA}$  Free-electron Laser, , 1990.

# THE APS-U PROJECT: A MULTI-BEND ACHROMAT (MBA) LATTICE

$$\varepsilon_x = C_L \frac{E^2}{N_D^3}$$

$C_L = \text{constant}$   
 $E = \text{beam energy}$   
 $N_d = \text{dipoles per sector}$

## APS MBA Upgrade:

Beam energy: 7 GeV  $\Rightarrow$  6 GeV

Dipoles per sector: 2  $\Rightarrow$  7

$10^2$  to  $10^3$  X  
increase in  
brightness

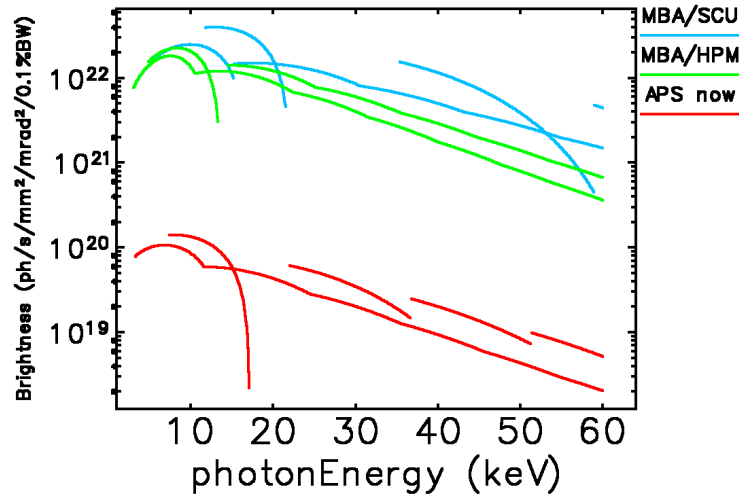

~50-fold  
reduction in  
horizontal  
emittance

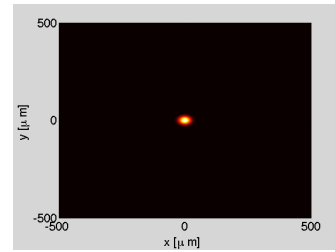
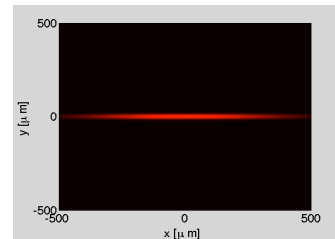
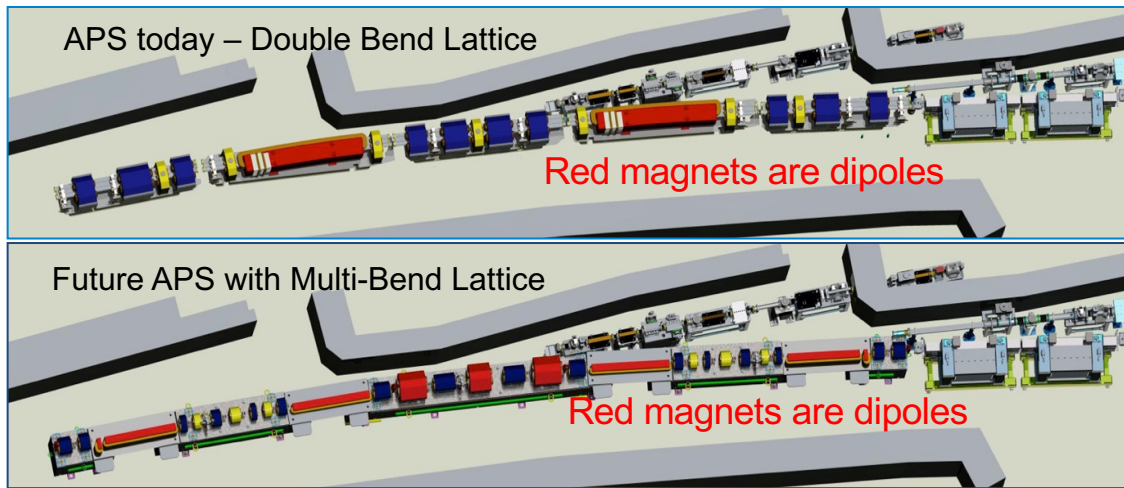

# APS-U Project Scope

## Feature beamlines

- Suite of beamlines, including long beamlines, designed for best-in-class performance

Total Project Cost - \$815M

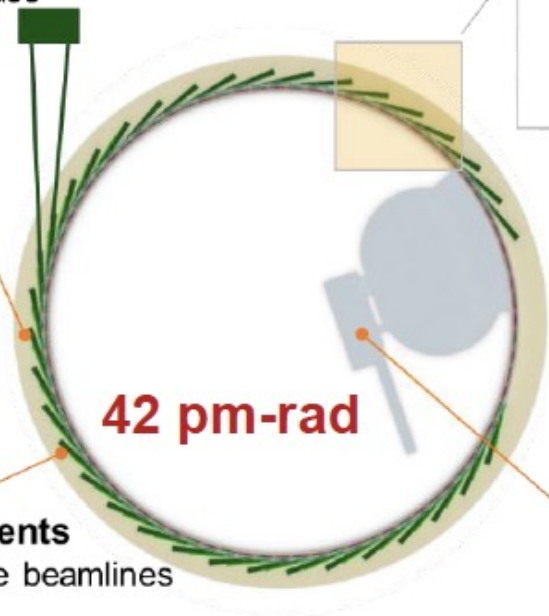

## New storage ring

- 6 GeV with 200 mA, 42 pm-rad emittance
- Hybrid 7BA lattice with reverse bends
- Improved electron and photon stability

## New insertion devices

- Including superconducting undulators

## New/upgraded front ends

## Injector improvements

- Increase performance beyond present capability

**On-axis “swap-out” injection**

## Beamline enhancements

- Improvements to make beamlines “Upgrade Ready”
- Existing beamlines are planned to come back on-line after the upgrade

# HIGHER MAGNETIC FIELDS FOR FOCUSING REQUIRES SMALL VACUUM CHAMBERS

Q1, Q3, Q6 Constraints

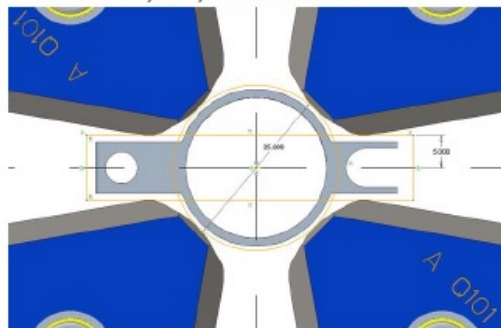

The small vacuum chamber permits the focusing magnets pole pieces (blue in fig. on right) to get closer to the electron beam producing higher magnetic focusing fields

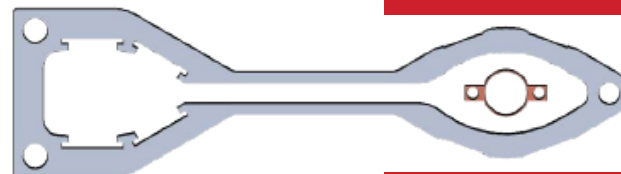

Existing APS storage ring through the dipole (bending) magnets compared to the APS-U vacuum chamber.

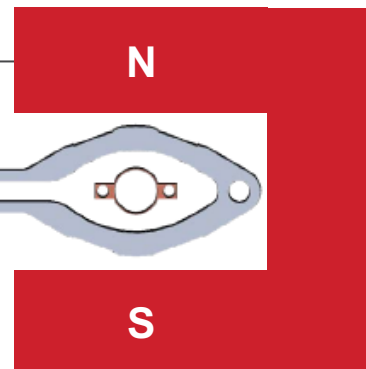

Dipole Magnet



Close-up of one of the 1,321 magnets that will make up the new APS electron storage ring.



More than 60 of the needed 200 magnet modules have been partially assembled and are in storage.

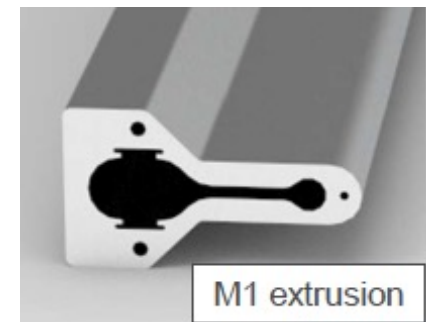

Dipole vacuum chamber for APS-U

# MBA UPGRADES – A COMPETITIVE LANDSCAPE

## ESRF (France)

- Upgrade is complete and ESRF/Extremely Bright Source (EBS) is operational

## MAX-IV (Sweden)

- A new (green field site) 3 GeV MBA lattice-based storage ring that is operational

## SIRIUS (Brazil)

- A new (green field site) 3 GeV MBA lattice-based storage ring that is operational

## SPRING-8 (Japan)

- Planning an MBA upgrading in 2020's

## ALS-U (US)

- Planning an MBA upgrading in 2020's

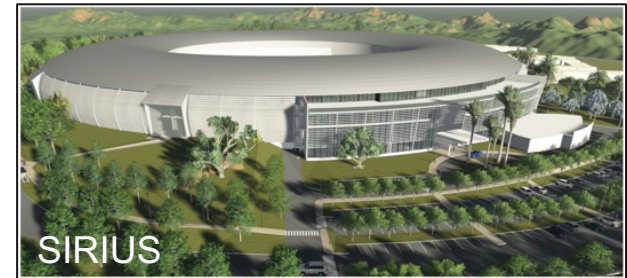

# SUMMARY

- Synchrotron radiation continues to be an important tool for researchers across all scientific and engineering disciplines.
- There is a strong science case for a new generation of sources such as:
  - Low-emittance storage rings
  - X-ray free electron lasers
- Storage rings can produce partially coherent x-ray beams with megahertz repetition rates but with lower peak intensity.
- FELs can provide very short pulses (femtoseconds) of high peak intensity, coherent x-rays but the repetition rate of many FELs limited to hundreds of hertz.
  - Superconducting radio frequency (SCRF) linacs will increase rep rates that to MHz (LCLS II and the European XFEL).
- The LCLS II, APS-U, and the upgrade for the Advanced Light Source (ALS-U at LBNL) will keep US x-ray facilities at the cutting edge to produce world class science in the years to come.



# REFERENCES

*“Introduction to Synchrotron Radiation”* by Giorgio Margaritondo

*“Synchrotron Radiation Sources – A Primer”* by Herman Winick

*“Undulators, Wigglers, and their Applications”* Edited by H. Onuki and P. Elleaume

*“Elements of Modern X-ray Physics”* by Jens Als-Nielsen and Des McMorrow

*“Third-Generation Hard X-Ray Synchrotron Radiation Sources: Source Properties, Optics, and Experimental Techniques”*, Edited by Dennis M. Mills

*“Synchrotron Radiation and Free-Electron Lasers: Principles of Coherent X-Ray Generation”*, by Kwang-Je Kim, Zhirong Huang and Ryan Lindberg

*“Handbook of Accelerator Physics and Engineering”*, Edited by A. Cho and M. Tigner

**QUESTIONS?**

# APPENDIX 1: RADIATED POWER FROM CHARGES AT RELATIVISTIC VELOCITIES

The classical formula for the radiated power from an accelerated electron is:

$$P = \frac{2e^2}{3c^3} a^2$$

Where  $P$  is the power and  $a$  the acceleration. For a circular orbit of radius  $r$ , in the non-relativistic case,  $a$  is just the centripetal acceleration,  $v^2/r$ . In the relativistic case:

$$a = \frac{1}{m_o} \frac{dp}{d\tau} = \frac{1}{m_o} \gamma \frac{d\gamma m_o v}{dt} = \gamma^2 \frac{dv}{dt} = \gamma^2 \frac{v^2}{r}$$

Where  $\tau = t/\gamma =$  proper time,  $\gamma = 1/\sqrt{1-\beta^2} = E/m_o c^2$  and  $\beta = v/c$

$$P = \frac{2e^2}{3c^3} \frac{\gamma^4 v^4}{r^2} = \frac{2ce^2}{3r^2} \frac{E^4}{m_o^4 c^8}$$

# DEPENDENCE ON MASS AND ENERGY OF RADIATED POWER

$$P = \frac{2e^2}{3c^3} \frac{\gamma^4 v^4}{r^2} = \frac{2ce^2}{3r^2} \frac{E^4}{m_o^4 c^8}$$

There are two points about this equation for total radiated power:

1. Scales inversely with the mass of the particle to the 4<sup>th</sup> power (protons radiate considerably less than an e<sup>-</sup> with the same total energy, E.)
2. Scales with the 4<sup>th</sup> power of the particle's energy (a 7 GeV storage ring radiates 2400 times more power than a 1 GeV ring with the same radius)

## APPENDIX 2: BM SPECTRAL DISTRIBUTION

The spectral/angular distribution of "synchrotron radiation" was worked out by J. Schwinger in 1949. Schwinger found the spectral distribution from an accelerating particle, under the influence of a constant magnetic field, was a smoothly varying function of photon energy and that the spectrum could be parameterized by a critical energy,  $E_c$ .

$$E_c = 3hc\gamma^3/4\pi r.$$

Here  $h$  is Planck's constant and  $r$  the radius of curvature of the trajectory. Note that the **critical energy scales as  $\gamma^3$** . In practical units, the critical energy can be written as:

$$E_c[\text{keV}] = 2.218 E^3[\text{GeV}] / \rho[\text{m}] = 0.06651 B[\text{kG}] E^2[\text{GeV}]$$

At the APS the bending magnets have a field strength of 5.99 kilogauss and the ring operates at  $E = 7$  GeV . The critical energy of the radiation emitted from the BM is:

$$E_c[\text{keV}] = 0.06651 B[\text{kG}] E^2[\text{GeV}]$$

or

$$E_c = 0.06651(5.990)(7^2) = \underline{19.5 \text{ keV}} \text{ or } \underline{0.64 \text{ \AA}}.$$

# APPENDIX 3: WHERE DID “K” COME FROM?

$$F_x = ma_x = \gamma m_0 \dot{v}_x = e\vec{v} \times \vec{B} = ecB_0 \sin\left(\frac{2\pi z}{\lambda_{TD}}\right)$$

$$\dot{v}_x = \frac{ecB_0}{\gamma m_0} \sin\left(\frac{2\pi z}{\lambda_{TD}}\right) \quad z = ct$$

$$v_x = -\frac{ecB_0}{\gamma m_0} \frac{\lambda_{TD}}{2\pi c} \cos\left(\frac{2\pi ct}{\lambda_{TD}}\right) = -\frac{eB_0}{\gamma m_0} \frac{\lambda_{TD}}{2\pi} \cos\left(\frac{2\pi ct}{\lambda_{TD}}\right)$$

$$x = \frac{eB_0}{\gamma m_0 c} \left[\frac{\lambda_{TD}}{2\pi}\right]^2 \sin\left(\frac{2\pi ct}{\lambda_{TD}}\right) = \left[\frac{eB_0}{m_0} \frac{\lambda_{TD}}{2\pi c}\right] \frac{1}{\gamma} \left[\frac{\lambda_{TD}}{2\pi}\right] \sin\left(\frac{2\pi z}{\lambda_{TD}}\right) = K \frac{1}{\gamma} \left[\frac{\lambda_{TD}}{2\pi}\right] \sin\left(\frac{2\pi z}{\lambda_{TD}}\right)$$

$$x_{\max} = K \frac{1}{\gamma} \left[\frac{\lambda_{TD}}{2\pi}\right] \quad \text{and} \quad \left[\frac{dx}{dz}\right]_{\max} = \frac{K}{\gamma} \quad \text{where} \quad K = \left[\frac{eB_0}{2\pi} \frac{\lambda_{TD}}{m_0 c}\right]$$

Equation of motion for a relativistic charged particle in a magnetic field

Magnetic field in y-direction and electron traveling in z-direction

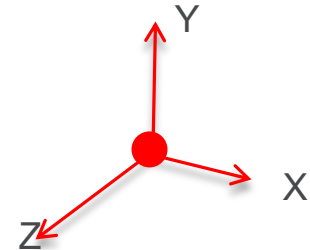

# APPENDIX 4: THE DIFFRACTION LIMITED OF LIGHT

- The Heisenberg Uncertainty Principle sets a lower limit for the product of the size  $\Delta x$  ( $\Delta y$ ), and angular divergence  $\Delta x'$  ( $\Delta y'$ ), of radiation. Recall:

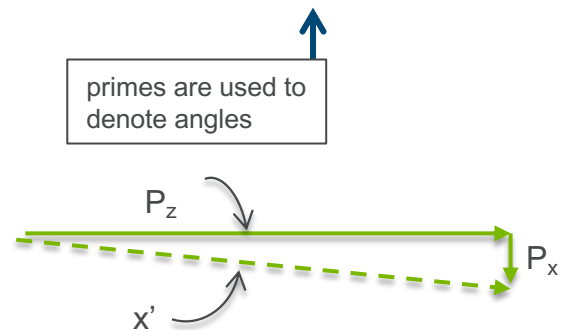

For radiation from relativistic electrons,  $x'$  ( $y'$ ) is proportional to  $P_x$  (small angle approximation).

$$\Delta x \Delta p_x \geq \hbar / 2$$

$$\frac{p_x}{p_z} = x' \text{ or } \frac{\Delta p_x}{p_z} = \Delta x' \text{ and } p_z = \hbar k = \frac{\hbar(2\pi)}{\lambda}$$

$$\text{so: } \Delta x \Delta p_x = \Delta x \Delta x' p_z = \Delta x \Delta x' \left[ \frac{\hbar(2\pi)}{\lambda} \right] \geq \hbar / 2$$

$$\Delta x \Delta x' \geq \lambda / 4\pi$$

- This says, for a given wavelength  $\lambda$ , the product of its size and divergence cannot be less than  $\lambda/4\pi$ . When the product is  $\approx \lambda/4\pi$  in both the x and y directions, the radiation is **fully coherent and the source is said to be diffraction limited**.

# APPENDIX 5: TUNING CURVES FOR UNDULATORS

- What is typically shown for the output of an undulator is not the spectrum at one gap setting but rather the energy range that can be covered over the available from the minimum gap.

The lowest x-ray energy (highest magnetic field) is set by the minimum magnet gap (determined by vertical size of the vacuum chamber).

As the gap is opened, the magnetic field gets smaller and the constructive interference occurs at higher x-ray energy. But when the magnetic field decreases so does the intensity so that limits the useful high energy range.

Here is the spectrum generated by an undulator for a particular magnetic gap or K value.

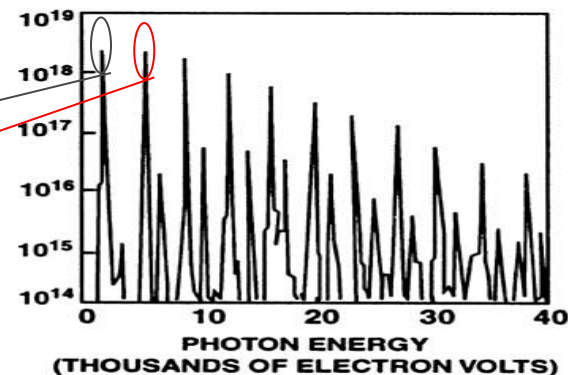
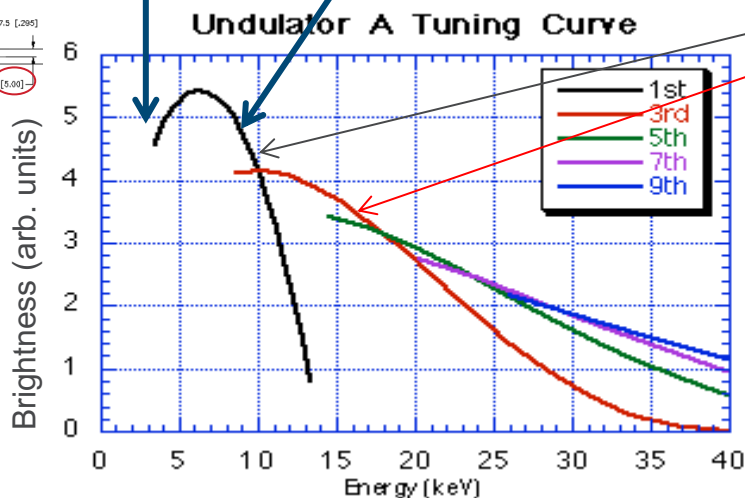
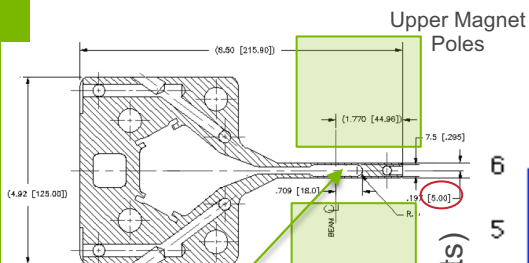

Plots like this that show the energy range that can be covered by an undulator are often called “tuning curves”.



# APPENDIX 6: X-RAY FREE ELECTRON LASERS (XFELs)

- Another way to reduce the particle beam emittance is through linac-based x-ray free electron lasers (XFELs)
  - Full transverse (spatial) coherence and femtosecond pulses
- An **x-ray FEL** uses the high brightness of an **electron gun** coupled to an **emittance-preserving linac**. You don't have to deal with the equilibrium transverse and longitudinal beam size (length of pulse) that occurs in a storage ring so can have a very low emittance and **very short pulses** (femtoseconds).

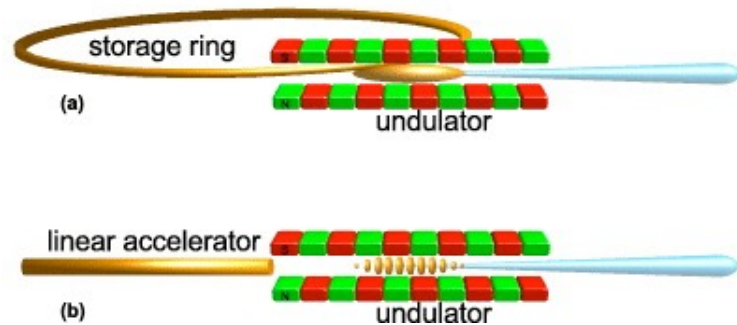

- The problem with a linac is you only use the electrons once, and so have to accelerate new electrons for each pulse. The acceleration process is what takes all the electrical power so a different paradigm is required. (In the storage ring you “recycle” the electrons after they have been accelerated up to energy and there is no further increase in particle beam energy as they go around.)

# GETTING THE ELECTRONS TO RADIATE IN PHASE

- When the electrons in a storage ring go through the undulator, there is no correlation between their positions on the scale of the radiation wavelength. As a result the fields they generate superimpose at random and its intensity is proportional to the number of electrons,  $N_e$ .
- If we could order the electrons so that they are all lined up in thin sheets, periodically spaced with spacing equal to the radiation wavelength, the radiation fields would superimpose in phase. The intensity is then proportional to  $N_e^2$ .
- Since  $N_e$  is a billion or more, one could obtain a huge gain.

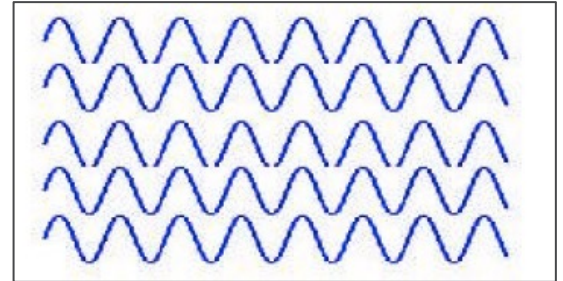
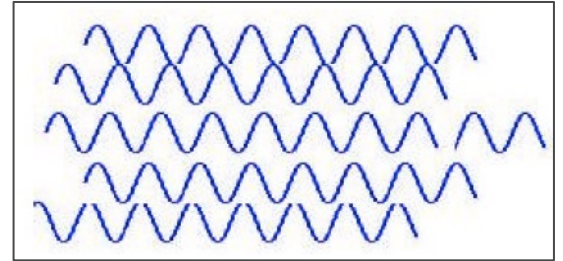

See P. Fuoss' talk for more details.

# SUMMARY OF THE FEL PROCESS

- The electrons **slip** behind the EM wave by  $\lambda_1$  per undulator period  $\lambda_u$ .
- Due to this sustained interaction, some electrons lose energy, while others gain energy -> **energy modulation at  $\lambda_1$**
- In the undulator magnetic field, the trajectory of electrons with larger (smaller) energy is bent less (more) -> **micro-bunching at  $\lambda_1$**
- Micro-bunched beam radiates coherently at  $\lambda_1$ , and in turn this interaction is enhanced -> **exponential growth of radiation power (gain)**
- This process is called Self-Amplified Spontaneous Emission (SASE)

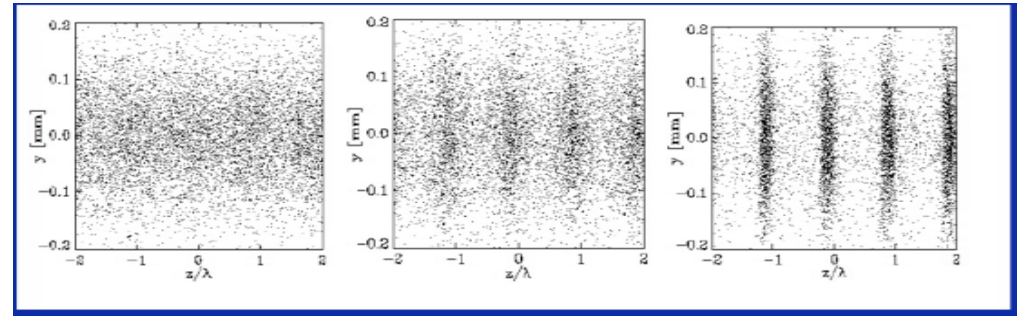
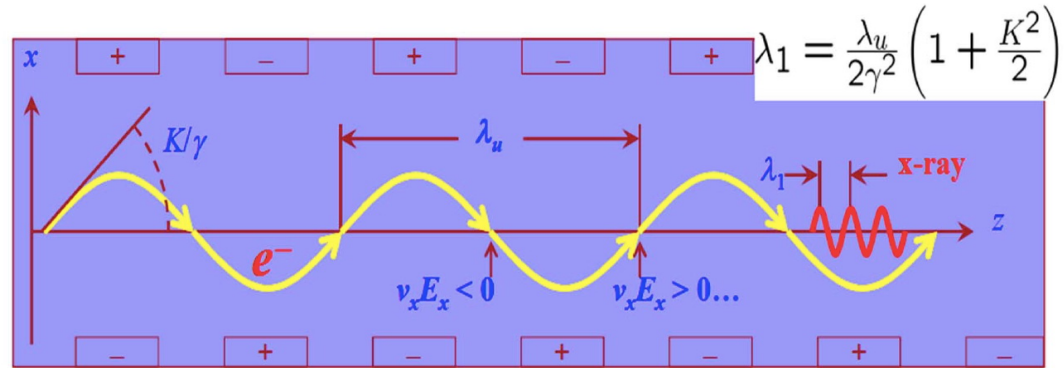

*X-ray free-electron lasers: An introduction to the physics and main characteristics*, P. Musumeci, Department of Physics and Astronomy, UCLA