



SUPER-NUOVA Multi-Place Stirrer and Stirring Hot Plates

OPERATION MANUAL
AND PARTS LIST
SERIES 1359 and 1360

Model #	Voltage	Description
S136030-33	220-240	Stirrer
S136035	120	Stirrer
SP135930-33	220-240	Stirring Hot Plate
SP135935	120	Stirring Hot Plate

Table of Contents

Safety Information	3
Alert Boxes	3
Warnings	3
General Specifications	5
Heating Specifications	6
Stirring Speed Specifications.....	6
Environmental Conditions	7
Declaration of Conformity	7
Introduction.....	8
General Usage.....	9
Unpacking and Installation	10
Unpacking	10
Installation	10
Principles of Operation.....	12
Operation	13
Power Button	13
Using the Stirring Function	13
Using the Heating Function	15
Controlling Solution Temperature with an External Probe.....	16
Using Preset Programs	17
Heating Metal Vessels and Sand Baths	17
Setting the Timer	17
Power Interruption Protection	18
Resume Button	18
Using the Probe with the Temperature Display for Stirring-only Applications	18
RS232 Output	19
Using HyperTerminal w/RS232	20
To Capture Data w/HyperTerminal.....	21
Service and Calibration	22
Service Menu.....	22
Over-Temperature Set Point - OSP.....	23
Temperature Probe Calibration - CAL	24
Oil Bath Method of Calibration	25
System Method of Calibration	26
Thermometer Mode - Prb	28
Timer Shutdown - End	28
Probe Temperature Limit - PL	29
Probe Response - Pr	30
Set Point Limit - SL	31
Error Disable - Err	31
Factory Defaults - deF	32
Model Selection - SEL	33
Flash Upgrade - FLS	34
General Cleaning Instructions	34
Troubleshooting Guide	35
Error Codes	35
Exploded Views	37
Wiring Diagram.....	41
Replacement Parts List	43
Accessories	44
Ordering Procedures	45
Warranty.....	48

Safety Information

Alert Signals



Warning

Warnings alert you to a possibility of personal injury.



Caution

Cautions alert you to a possibility of damage to the equipment.



Note

Notes alert you to pertinent facts and conditions.



Hot Surface

Hot surfaces alert you to a possibility of personal injury if you come in contact with a surface during use or for a period of time after use.



Note

The SUPER-NUOVA Multi-Place plates are not explosion proof. If explosion proof models are required, contact customer service at 1-800-553-0039 for more information.



Warning

Refer servicing to qualified personnel.

Your Thermo Scientific SUPER-NUOVA Multi-Place Plate has been designed with function, reliability, and safety in mind. It is your responsibility to install it in conformance with local electrical codes. For safe operation, please pay attention to the alert signals throughout the manual.

Warning: These products should be used only under the operating conditions specified in the Operating Manual. Always use safe laboratory practices and do not leave the hotplate in operation while unattended as product functionality or laboratory practice failures could occur that might lead to uncontrolled or excessive heating of the top surface. Safety procedures (including, but not limited to, unplugging when not in use) and response plans should be put in place to address the worst case possibility. If an over-temperature failure occurs, the top surface temperature could rise to the maximum temperature (300-540°C depending on your model's specification) and remain at that temperature indefinitely. Under these conditions, the material being heated on the surface of the hotplate could reach levels in excess of the maximum temperature.

This manual contains important operating and safety information. The user must carefully read and understand the contents of this manual prior to the use of this equipment.

Warnings

To avoid electrical shock, always:

1. Use a properly grounded electrical outlet of correct voltage and current handling capacity.
2. Disconnect from the power supply prior to maintenance and servicing.

To avoid personal injury:

1. Do not use in the presence of flammable or combustible materials — fire or explosion may result. This device contains components which may ignite such materials. Not rated for use in hazardous atmospheres.
2. Use caution when heating volatile materials; top surface and element can reach the "Flash Point Temperature" of many chemicals. These plates are not explosion proof. Fire or explosion may

SAFETY INFORMATION

result. Unit contains components which may ignite such materials.

3. Keep top surface clean. Use a non-abrasive cleaner. Alkali spills, hydrofluoric acid spills or phosphoric acid spills may damage top and lead to thermal failure. Unplug unit and remove spills promptly. Do not immerse unit for cleaning.
4. Replace the top immediately if damaged by etching, scratching or chipping. A damaged top can break in use.
5. Do not use metal foil on hot plate which may block air flow. Overheating will result.
6. Do not remove or modify grounded power plug. Use only properly grounded outlets to avoid shock hazard.
7. Use appropriate hand and eye protection when handling hazardous chemicals.
8. Gross weight of items placed on top of plates should not exceed 35 lbs. (15.9 kg.)
9. "Caution: Hot Top. Avoid Contact." The top plate of the unit can remain hot for some time after use. A "CAUTION - HOT TOP" light will remain on until top plate temperature cools to below 50°C.
10. Do not leave an active probe out of the fluid. This may cause uncontrolled heating of the fluid on the hot plate and unintentional boiling or an explosion could occur.
11. Localized heater element temperature can be significantly higher than the temperature indicated on the display. If flammable concentrations reach internal element, a fire could result.
12. Note that the exterior housing will be hot during use and for a period of time after use.
13. Refer servicing to qualified personnel.

General Specifications

Stirring Hot Plates

Model Number	SP135935	SP135930-33
Overall Dimensions in. (cm)		
Width	11.3" (28.7 cm)	11.3" (28.7 cm)
Height	4.0" (10.1 cm)	4.0" (10.1 cm)
Depth	16.2" (41.1 cm)	16.2" (41.1 cm)
Weight lbs (kg)	20.5 lbs (9.3 kg)	20.5 lbs (9.3 kg)
Top Plate		
Width	10.5" (26.7 cm)	10.5" (26.7 cm)
Height	1.0" (2.5 cm)	1.0" (2.5 cm)
Depth	10.5" (26.7 cm)	10.5" (26.7 cm)
Electrical Ratings		
Volts	120	220-240
Amps	11.8	6.1
Watts	1400	1450
Freq.	60	50/60
Phase	1	1
Max. Setpoint Temp. °F (°C)	698°F (370°C)	698°F (370°C)

Stirrers

Model Number	S136035	S136030-33
Overall Dimensions in. (cm)		
Width	11.3" (28.7 cm)	11.3" (28.7 cm)
Height	4.0" (10.1 cm)	4.0" (10.1 cm)
Depth	16.2" (41.1 cm)	16.2" (41.1 cm)
Weight lbs (kg)	20.5 lbs (9.3 kg)	20.5 lbs (9.3 kg)
Top Plate		
Width	10.5" (26.7 cm)	10.5" (26.7 cm)
Height	1.0" (2.5 cm)	1.0" (2.5 cm)
Depth	10.5" (26.7 cm)	10.5" (26.7 cm)
Electrical Ratings		
Volts	120	220-240
Amps	2.04	1.0
Watts	110	100
Freq.	60	50/60
Phase	1	1

GENERAL SPECIFICATIONS

Heating Specifications

Top Plate Surface - Solid Ceramic

Temperature range: 1°C - 370°C (34°F - 698°F)*

* This plate does not cool. The minimum temperature is 1°C if used in a cold room below 1°C.

Heat-up time to within 5°C of maximum temperature (unloaded top plate): 8 minutes

Temperature stability using remote probe (500 ml of water in a 1000 ml flask at 70°C): ±1.0°C

Accuracy of the temperature display vs. the actual average temperature of a 2" diameter at the center of the top plate (setpoint 100°C unloaded):* ± 10.0°C

Temperature stability at the center of the top plate surface: ± 2.0°C

Accuracy of remote probe at user selected calibration temperature after calibration procedure: ±0.5°C typical

**Accuracy of the temperature display vs. the actual average temperature of a 2" diameter at the center of the top plate unloaded and at set points other than 100°C will be approximate and relative to environmental, heat thermodynamics, and other variable conditions. If load accuracy is required, it is recommended to use the remote probe.*

Stirring Speed Specifications

Speed Range: 50 to 1200 RPM

Accuracy of stirring speeds above 200 rpm: ±2.0%

Stability of the stirring speed setpoint (600 ml of water in a 1000 ml glass flask above 200 rpm) ± 2.0%
(At speeds lower than 200 rpm, the powerful magnetic fields begin to interact with each other)

Top Plate Size
10" x 10"

Max Recommended Flask Size
Four 1 liter flasks

Max Weight on Top Plate
35 lbs.

Environmental Conditions

Operating:	0°C to 27°C; 20% to 80% relative humidity, non-condensing. Installation category II (overvoltage) in accordance with IEC 664. Pollution degree 2 in accordance with IEC 664. Altitude Limit: 2,000 meters.
Storage:	-25°C to 65°C 10% to 85% relative humidity

Declaration of Conformity

(for 220-240 volt, -33 CE models only)

We hereby declare under our sole responsibility that this product conforms with the technical requirements of the following standards:

EMC:	EN 61000-3-2 EN 61000-3-3 EN 61326-1	Limits for harmonic current emissions Limits for voltage fluctuations and flicker Electrical equipment for measurement, control, and laboratory use; Part I: General Requirements
Safety:	EN 61010-1 EN 61010-2-010 EN 61010-2-051	Safety requirements for electrical equipment for measurement, control, and laboratory use; Part I: General Requirements Part II: Particular requirements for laboratory equipment for the heating of materials Part II: Particular requirements for laboratory equipment for mixing and stirring

per the provisions of the Electromagnetic Compatibility Directive 89/336/EEC, as amended by 92/31/EEC and 93/68/EEC, and per the provisions of the Low Voltage Directive 73/23/EEC, as amended by 93/68/EEC.

The authorized representative located within the European Community is:

Thermo Fisher Scientific
419 Sutton Road
Southend On Sea
Essex SS2 5PH
United Kingdom

Copies of the Declaration of Conformity are available upon request.

Introduction



Super Nuova Multi-Place

Please read all the information in this manual before operating the unit.

Your SUPER-NUOVA Multi-Place plate is a heating and/or stirring plate designed for laboratory procedures requiring precise control of temperature and/or stirring speed. Each SUPER-NUOVA Multi-Place includes a digital display for monitoring temperature and/or stirring speed, and the stirring hot plate models have dual displays so temperature and stirring speed can be monitored simultaneously. The hot plate is capable of producing accurately controlled top plate temperatures from 1°C through 370°C. The temperature is controlled at the plate surface by an internal Type K thermocouple sensor, or the solution temperature may be controlled by utilizing the included 6" PFA encapsulated ungrounded stainless steel Type K thermocouple probe. A 6" or 10" general purpose stainless steel immersion probe, or a chemical-resistant 7" solid Teflon® immersion probe may be ordered separately. The stirrer will accurately maintain stirring speeds from 50 rpm up to 1200 rpm. On stirring hot plate models, the accessory probe may also be utilized to display the actual temperature of heat-sensitive solutions during stirring-only functions. The top plate on the SUPER-NUOVA Multi-Place plates are solid ceramic, and are suitable for use with glass or metal vessels and sand baths.

Other features of the SUPER-NUOVA Multi-Place include a timer that can be used to shut off stirring, heating or both. Specific temperature or stirring speed setpoints may be set using the PRESETS buttons on the SUPER-NUOVA Multi-Place. An over temperature protection (OTP) circuit can be set using the adjustment on the front face of the unit. The OTP can be displayed in the service menus. See "Service and Calibration."

An RS232 port is available on the SUPER-NUOVA Multi-Place to output elapsed time, stirring setpoint (for each of the stirring positions), actual stirring speed (for each of the stirring positions), heating setpoint, and actual temperature. (Actual temperature refers to top plate temperature, or remote probe temperature if a probe is being used.) The data is printed once every second when the unit is powered on (displays on). See "RS232 Output" in the Operation section of this manual.

Your SUPER-NUOVA Multi-Place may be used for gener-

al purpose heating applications and/or general laboratory mixing of solutions, including sample preparation, heating reagents, melting paraffin, warming resinous chemicals, content analysis, solvent evaporations, digestions, media preparation and sterilization, titrations, sand baths, and microscale chemistry applications.

General Usage

Do not use this product for anything other than its intended usage.

Unpacking and Installation



Warning

Use a properly grounded electrical outlet of correct voltage and current handling capacity.

Do not remove or modify grounded power plug. Use only properly grounded outlets to avoid shock hazard. Not rated for use in hazardous atmospheres.

Do not use in the presence of flammable or combustible materials; fire or explosion may result. This device contains components which may ignite such materials.

If explosion proof models are required, contact customer service at 1-800-553-0039 for more information.

Do not use in highly corrosive atmospheres; corrosive fumes and spills may damage top and internal components, creating shock hazard.



Note

Some misalignment of the motor bearings in this product may have occurred during shipping. Prior to using this product, run the stirrer at maximum speed for ten minutes to realign the bearings.

Unpacking

Remove your SUPER-NUOVA Multi-Place from the carton. Inspect to ensure that the unit has not been damaged during shipment. If the unit appears to have sustained shipping damage contact the distributor from whom you purchased this product or Customer Service at 800-553-0039. Check for stir bar, remote probe and thumbscrew prior to discarding packaging.

The following items are included in the shipment:

SUPER-NUOVA Multi-Place Plate

Stir Bar - ZSX65A

Remote Probe - TCX16

Ring Stand Knob - KBX106

Operator's Manual - LT1359X1

If any of these items are missing from the carton, contact Customer Service.

Installation

Set the unit on a flat stable surface at least 12" away from combustible materials, and plug the cordset into a properly grounded electrical outlet of correct voltage and current handling capacity.

UNPACKING AND INSTALLATION



Cord retention clip

RS232 Port Connections

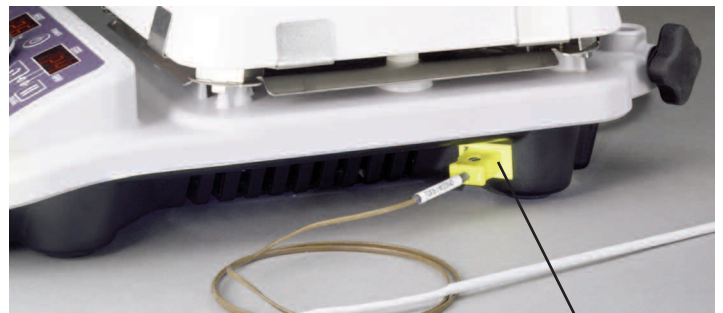

Remote Probe Connection

Below is the control panel of the SUPER-NUOVA Multi-Place stirring hot plate. The stirrer control panel is the same except for any buttons referring to temperature.

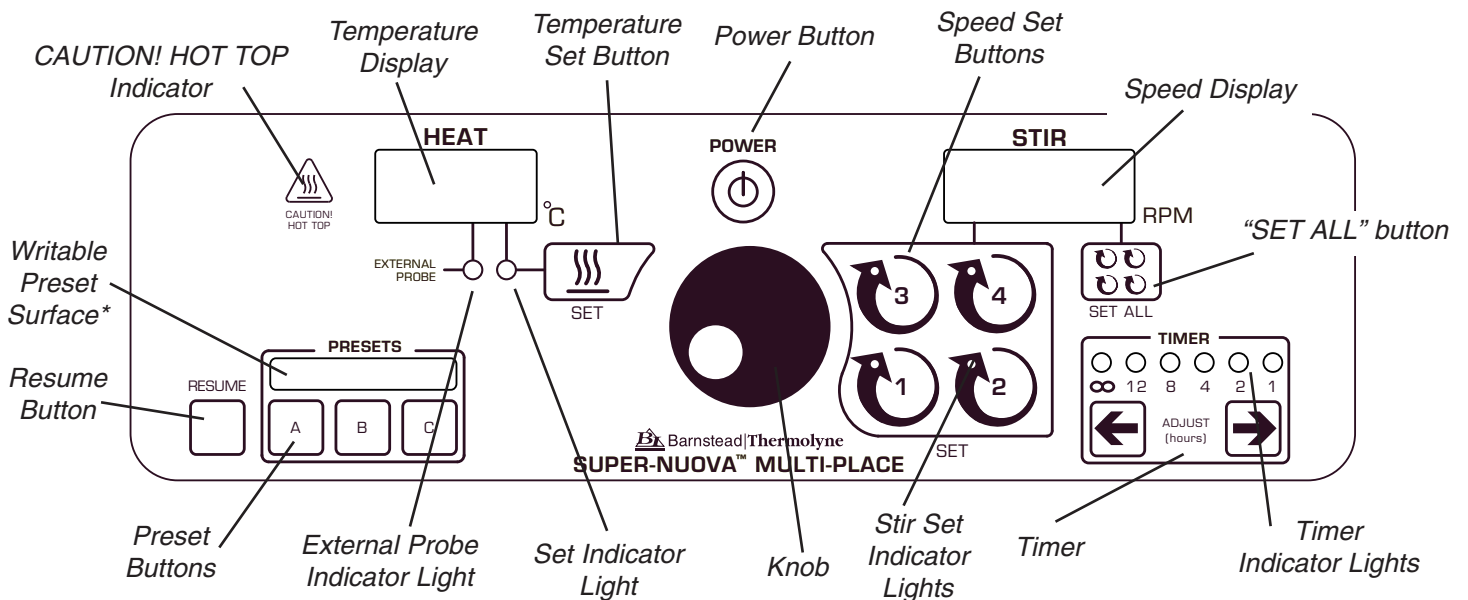

*Use only a No. 2 pencil to gently mark up writable preset surface.

Principles of Operation



Note

This plate does not cool. The minimum temperature is 1°C if used in a cold room at 1°C.

Each SUPER-NUOVA Multi-Place utilizes the latest micro-processor technology to deliver the most reliable, accurately controlled, ceramic top plate on the market.

Your SUPER-NUOVA Multi-Place has an electronic, closed-loop feedback control which will maintain temperature setpoints from 1°C through 370°C.

The SUPER-NUOVA Multi-Place plates use a Type K thermocouple for measuring the top plate temperature, OTP and the external probe. Both top plate surface and OTP temperature are measured with independent analog circuits. This provides a significant increase in safety due to the redundancy of the circuits. It is possible to heat certain types of metal vessels and sandbaths on the SUPER-NUOVA Multi-Place without damaging the ceramic top.

The electronic stirring speed control will maintain the speed setpoint when the unit is loaded. The motor is combined with a powerful magnet to provide exceptional magnetic coupling with a stir bar.

The timer feature on the SUPER-NUOVA Multi-Place can be programmed to turn off the stirring, heating or both. The default setting is to turn off heating only. See “Setting the Timer” section of this manual. To change default setting, see “Service and Calibration/Timer Shutdown”.

Use the space-saving, SUPER-NUOVA Multi-Place stirrer or stirring hot plate to perform multiple operations at once.

Operation



Note

When the unit is initially plugged into a power source, or when it is unplugged and re-plugged in, the display will flash dashes and zeros for a few seconds. This is simply an initial check.



Note

The knob does not function unless one of the “SET” buttons is pushed first to activate it. Pushing the knob alone has no function.

Power Button

The SUPER-NUOVA Multi-Place has a power button located on the front control panel. The unit may be powered on by pressing the power button or ANY button on the control panel. When the stirring hot plate unit is turned on, there will be three beeps, the unit will initialize and then “OFF” will be displayed on the “HEAT” and “STIR” display screens until a temperature and/or stirring speed are entered. When the stirrer unit is turned on, there will be three beeps, the unit will initialize and then “OFF” will be displayed on the “STIR” display screen until a stirring speed is entered. To turn off power to the unit, press the power button.

Using the Stirring Function

The SUPER-NUOVA Multi-Place has an electronic feedback speed control which will maintain a precise speed setpoint from 50 rpm through 1200 rpm. Stirring speed stability is 2.0% at speeds greater than 200 rpm. (Maximum speed is dependent on viscosity of the solution.) The SUPER-NUOVA Multi-Place plates are equipped with a strong magnet and high torque motor which will draw a vortex in fluids up to 700 cp.

To set the stirring speed, press desired stirring position key (1-4) located under the STIR display. Use the knob in the center of the console to select a speed. Turn the knob clockwise to increase the speed or counterclockwise to decrease the speed. When desired speed has been reached, press same key (1-4) under the STIR display or wait a moment and the unit will beep indicating that it has been set. Repeat for each individual stirring position. After stirring speeds have been set, the indicator lights will alternate to each position, displaying each stirring setpoint.

To set all positions to the same stirring speed, press the “SET ALL” key under the STIR display. Use the knob in the center of the console to select a speed. Turn the knob clockwise to increase the speed or counterclockwise to decrease the speed. When desired speed has been reached, press the “SET ALL” key again or wait a moment and the unit will beep indicating that it has been set.

**Note**

Each motor can be paused individually or all motors at the same time. See recommendations for best performance when using low stirring speeds.

Once the unit begins stirring, the display will register ACTUAL speed until the setpoint has been reached. To check the setpoint, press the corresponding stirring position key (1-4 or "SET ALL") and your setpoint will be displayed again for a few seconds. The display will automatically return to indicating actual speed. To stop the stirring action without changing your setpoint press the position 1-4 or "SET ALL" button, *and hold* until you hear a beep. "PAUSE" will scroll across the display. To resume stirring at the set speed, quickly press the the corresponding button again. You can pause all positions at once, by using the "SET ALL" button, or pause individual positions.

To turn stirring off, press desired stirring position key (1-4 or "SET ALL") under the STIR display and turn the knob counterclockwise until the display reads "OFF." It is possible to turn off all positions, even if the stirring speeds were individually set and not by using the "SET ALL" key. To turn stirring off to all positions, press "SET ALL" and turn the knob counterclockwise until "OFF" is displayed.

For best performance at low stirring speeds, leave all four motors running. If stirring is not desired in one or more locations, take stir bar(s) out of flasks at those locations and allow all four motors to run, rather than stop or pause unused motor(s).

**Warning**

Use caution when heating volatile materials; top surface and element can reach the “Flash Point Temperature” of many chemicals. These plates are not explosion proof. Fire or explosion may result. Unit contains components which may ignite such materials.

Use appropriate hand and eye protection when handling hazardous chemicals.

“Caution: Hot Top. Avoid Contact.” The top plate of the unit can remain hot for some time after use. A “CAUTION - HOT TOP” light will remain on until top plate temperature cools to below 50°C.

**Note**

The temperature display will indicate the actual temperature of the top plate (1°-370°C). This plate does not cool. The minimum temperature is 1°C if used in a cold room at 1°C.

**Note**

Boiling times are dependent on solution volume and the surface area of the flask that is exposed to the hot plate. For example, when heating the same amount of solution in a 2L flask vs. a 1L flask, the solution will heat about 20% faster.

**Note**

The top plate temperature will be higher than your solution temperature. Use external probe to read actual solution temperature.

Using the Heating Function

The SUPER-NUOVA Multi-place stirring hot plate has an electronic closed-loop feedback control which will maintain temperature setpoints from 1°C above ambient through 370°C. An unloaded hot plate will heat to maximum temperature in just 8 minutes. A “CAUTION HOT TOP” light on the front panel will illuminate whenever the top surface temperature exceeds 50°C. The temperature may be controlled either at the top plate by the internal Type K thermocouple sensor, or in the solution using an accessory ungrounded Type K thermocouple probe. If a probe is used, the “External Probe” light will be illuminated on the front panel. A 6” chemically resistant stainless steel remote probe is included with the unit, alternatively a 6” or 10” stainless steel general purpose immersion probe, or a chemical-resistant 7” Teflon immersion probe are available by calling customer service. See the Accessories section of this manual. The SUPER-NUOVA Multi-Place will accept any ungrounded Type K thermocouple probe, however the accuracy of probes other than those tested and specified may not reach the probe accuracy rating designated.

To set the temperature, press “SET” key located under the HEAT display. The red set temperature indicator light will blink, indicating it is ready to be set. Use the knob in the center of the console to select a temperature. Turn the knob clockwise to increase the temperature or counterclockwise to decrease the temperature. When desired temperature has been reached, press the “SET” key under the HEAT display or wait a moment and the unit will beep indicating that it has been set. All plate positions will heat to the same settings. You can not specify different heating setpoints for the different positions.

Once the unit begins heating, the display will register ACTUAL temperature until the setpoint has been reached. To check your setpoint, press “SET” under the HEAT display and your setpoint will be displayed again for a few seconds. The display will automatically return to indicating actual temperature. Keep in mind, drafts and other temperature fluctuations will affect temperature accuracy.

Controlling Solution Temperature Using External Probe

To control the solution temperature plug the included probe or an ungrounded Type K thermocouple probe into the probe receptacle located on the right side of the unit. Be careful to observe the correct polarity of the probe connector when inserting probe. Place the probe into the solution. The display will indicate the actual temperature of the solution as measured by the probe, and the probe indicator LED on the front panel will be illuminated. Keep in mind, drafts and other temperature fluctuations will affect temperature accuracy.



Note

Only one external probe can be plugged into the SUPER-NUOVA Multi-Place, therefore only one of the four positions can be monitored in this manner.

The external probe offers more exact temperature control than regulating the top plate by the internal sensor. If you need to maintain a precise setpoint it is recommend to use a probe to control the solution temperature instead of controlling by the top plate temperature.

When using a probe with the SUPER-NUOVA Multi-Place stirring hot plate it is recommended that a clamp on a support rod be used to hold the probe in the solution.

To ensure accurate probe readings, as much of the probe sheath as possible should be immersed in the solution. Make sure the probe is immersed in the liquid and is not located in air or outside of the solution in the center of the stirring vortex. If the probe is plugged into the stirring hot plate, but is not in solution while the heat control is operating, the temperature display will continue to indicate an ambient temperature, and a probe out of solution error will occur. Because the set point cannot be reached the element will continue to supply heat to the top plate, and the top plate temperature of 370°C may be reached. If the remote probe does not sense a temperature change in 9 minutes the unit will display a heating error and shut down. If more or less than 9 minutes is required, see “Service and Calibration/Probe Response.”

Using Preset Programs

The SUPER-NUOVA Multi-Place features the option of pre-setting 3 setpoints into its memory (A, B or C.) To program a preset, adjust the heat and/or stir features to your desired setpoints. Press and hold one of the presets and the unit will beep indicating those setpoints have been stored in memory. The presets will be held in memory, even if the unit is unplugged, until you choose to override it with another preset.

To activate one of the presets, quickly press the corresponding letter and the stir and/or heat features will automatically adjust themselves.

A No. 2 pencil may be used to gently mark up writable preset surface.

Heating Metal Vessels and Sand Baths

Metal vessels and sand baths cannot be heated on most solid ceramic tops because of the tendency for the metal and the sand to reflect heat back into the top, eventually exceeding the maximum temperature rating for a ceramic top, which can cause it to break. Because of its advanced electronic control, the SUPER-NUOVA Multi-Place is capable of regulating the top plate temperature. Metal vessels and sand baths may be heated safely without the danger of the ceramic top breaking.

Setting the Timer

The timer function on the SUPER-NUOVA Multi-Place can be set to shut off stirring, heating or both, in all four positions at once. The timer can be set for a desired number of hours (1, 2, 4, 8 or 12) or for a non-specific period of time (Infinity symbol). To set the timer, use the right and left arrows until the light above the number corresponds to the desired time. The default setting is turning off heating only. To change this setting, see "Service and Calibration/Timer Shutdown."

If at any time you wish to reset the timer, press the right or left arrow keys until the indicator light corresponds to your desired time. The unit will beep indicating it has been reset.

One minute before shutdown, the unit will beep three times and flash the 1 hour light. The unit will beep three more times to indicate it has timed out.

Power Interruption Protection

If an interruption in power supplied to the SUPER-NUOVA Multi-Place occurs, the unit will resume normal operation after power is restored, *as long as the interruption is no longer than 10 seconds*. If the interruption is longer than 10 seconds, the unit's power will be off once the facility power is restored.



Note

The display on the stirring hot plate will indicated temperatures from 0 to 370°C when displaying temperature from a probe. If the actual temperature is below 0°, the display will still read 0. If the temperature is higher than 370°, the display will still read 370.

Resume Button

The resume button will recall the operation being performed when power is shut off to the unit. It applies to both a voluntary power-off by using the power button, or if power is lost due to an outage. If the outage lasts longer than 10 seconds, once restored press "POWER" then "RESUME" to recall the previous operation. If the power is lost for less than 10 seconds, the unit will automatically resume it's operation.

Using the Probe with the Temperature Display for Stirring-only Applications

On stirring hot plate models, the probe can also be utilized to monitor the actual temperature of your solution when you want to stir the solution without heating. The unit must be changed to "Thermometer" mode in order to perform this operation. See "Service and Calibration/ Thermometer Mode." To use the probe without heating the solution, turn the knob counterclockwise until the display indicates "OFF." The element will not supply heat to the top plate.

RS232 Output

An RS232 port is available on the SUPER-NUOVA Multi-Place to output elapsed time, speed, and temperature data. The data is printed once every second when the unit is powered on (displays on). A comma separates each piece of data so that it may easily be imported into a spreadsheet as CSV (Comma Separated Values). The actual data stream sent every second consists of: Elapsed Time, Stirring Setpoint (for each of the stirring positions), Actual Stirring Speed (for each of the stirring positions), Heating Setpoint, Actual Temperature. (Actual temperature refers to top plate temperature, or remote probe temperature if a probe is being used.)

Elapsed time is a 1 second counter that rolls over to zero again every 12 hours (43,200 seconds). The speeds are given in RPM, and the temperatures are given in degrees Celsius. When the unit is first powered on (displays turn on) a header will print indicating the columns.

In order to communicate with the SUPER-NUOVA Multi-Place, the computer connected to it needs to be set with the following parameters:

- BITS PER SECOND: 57,600
- DATA BITS: 8
- PARITY: NONE
- STOP BITS: 1
- FLOW CONTROL: NONE

Also, the first time a unit is plugged in, a paragraph of diagnostics information will be sent via RS232 and can be viewed with a terminal program. An example of the data that is sent is:

```
CSP,  COS
70,   0
```

CSP = Calibration Set Point
COS = Calibration Offset

The Calibration Set Point is the temperature that the unit was calibrated at when calibration was performed. The Calibration Offset is the offset determined at the calibration temperature.

Using HyperTerminal w/RS232

With HyperTerminal you can store the RS232 output data of a SUPER-NUOVA Multi-Place on a PC. NOTE: Other terminal programs that capture RS232 data can be used as well.

In order to follow this procedure, you must have:

- Microsoft Windows 95, or greater with HyperTerminal installed (it is available from the Windows installation CD if not installed already).
- A PC that has an available 9 pin DB-9 RS232 connector.
- WHX18 (Accessory) – PC to hot plate communications cable – Connect it from the back of the hot plate to the communications port desired.

To Setup HyperTerminal:

1. From the START menu of Windows, select ACCESSORIES, COMMUNICATIONS, HYPER-TERMINAL
2. Type in a name (example: SuperNuova) that you would like to refer to the connection by in the NAME box. You may also select an icon if you would like. Then select OK.
3. Select the RS232 port that you plan to use to connect to the hot plate (typically Com 1 or Com 2). Then select OK.
4. Under port settings, select the following:
 - BITS PER SECOND: 57,600
 - DATA BITS: 8
 - PARITY: NONE
 - STOP BITS: 1
 - FLOW CONTROL: NONE

Then Select OK.

5. Select FILE, SAVE AS, and save this setup wherever you would like it to be located (if you would like it on the Desktop, select Desktop) and select SAVE. You will be able to run HyperTerminal with this setup in the future by just double-clicking the icon if you put it on the Desktop.
6. The setup of HyperTerminal is now complete, you can view the past data, but the program will only allow you to see the past 500 lines in its buffer. To capture data permanently follow the Capture with HyperTerminal Instructions below.

To Capture Data With HyperTerminal

1. Start HyperTerminal by double-clicking on the Icon created in the Setup Procedure above.
2. Select TRANSFER, CAPTURE TEXT. Select the Folder and File name you would like to use to refer back to this data (example: C:\SuperNuova\ Test1.txt). It is important to use the txt extension so that when you double-click on the file at a later date, it will automatically open in a text viewing program, or it use the csv extension and it can be opened in a spreadsheet such as Excel.
3. The hot plate can be operated and the data will be stored (it is still viewable on-screen) to the file that was setup in the previous step.
4. The data file must be closed at the end of the day (or the end of the capturing session) by selecting TRANSFER, CAPTURE TEXT, STOP. The data file must be closed before shutting down the computer also.
5. The program may be exited by selecting FILE, EXIT. Select YES to the question "ARE YOU SURE YOU WANT TO DISCONNECT NOW?".

Service and Calibration

Service Menu

The Service Menu has many features that will allow a user to customize their unit.

A table of the features available in the Service Menu is given below. The features are given in order of their appearance in the Service Menu when rotating the center knob in a clockwise rotation. The Feature column is the name of the feature, the Display column is the designation of that feature as shown on the display of the unit, the Availability column gives which type of unit the feature is applicable (S = stirrer, and SP = stirring hot plate), and the last column gives a brief description of the purpose of the feature.

Feature	Display	Availability	Brief Description
Over-temperature Set Point	OSP	SP	Allow the user to see the setting of the Over Temperature Protection control.
Temperature Probe Calibration	CAL	SP	Allows calibration of the temperature probe and associated circuitry.
Thermometer Mode	Prb	SP	Allows the probe circuit to be used as a thermometer while still allowing independent use of the stirring control (if so equipped). Default is OFF.
Timer Shutdown	End	S, SP	When the timer elapses, a choice of what should turn off is selectable between heating, stirring, or both. Default is heating only (H) on SP and stirring only (S) on S.
Probe Temperature Limit	PL	SP	Allows the user to limit the maximum temperature of the heating set point, when the probe is attached, to 250° C or allow it to be unlimited. Default is 250° C.
Probe Response	Pr	SP	Sets the minimum time required for the probe temperature to rise before signaling an error (E03). This is adjustable from 3 to 20 minutes in 1 minute increments. Default is 9 minutes.
Set Point Limit	SL	SP	The maximum settable temperature can be limited to below the OSP, or can be unlimited. Unlimited can allow the OTP circuit to automatically disconnect relay power if the OSP setting is exceeded. Default is to be limited by the OSP.
Error Disable	Err	S, SP	All errors except E12 (locked rotor) can be disabled if they are presenting problems with the operation of a unit. Default is all errors enabled. Care must be exercised when changing the default.
Factory Defaults	dEF	S, SP	All settings listed in this table will be reset to the default factory setting. Useful in troubleshooting.
Model Selection	SEL	S, SP	Allows the unit to be configured as a stirrer, or stirring hot plate.
Flash Upgrade	FLS	S, SP	If a new version of firmware is obtained, it can be loaded into the device using this menu. All options will be set to factory defaults when complete.

**Note**

For most routines, the POWER key can be used to return to a previous menu if desired. Also, many of the options can be checked to see how the unit is configured by selecting the feature and observing which menu item is displayed. The unit will always display the current configuration first.

Over-temperature Set Point - OSP

This option is only available for units that have heating functionality. The Over-temperature Set Point is the set point of the independent temperature control. The purpose of the control is to limit the top temperature of the element independently of the standard heating control. This is helpful if there is a failure of the main control that would cause the top to heat excessively. The adjustment for this control is done at the front edge of the unit using a small straight blade screwdriver to make the adjustment. Typically the set point will be adjustable from 60 to 400°C in 10°C increments.

The Over-temperature Set Point can be viewed with this menu option. To do so, follow the instructions given below:

1. Plug the unit into the appropriate power, but do not turn it on (displays should be blank, unless Hot Top Warning System is indicating a hot surface), enter the Service Menu by pressing and holding the POWER key. After about 3 seconds a single beep will be heard and you may remove your finger from the POWER key. The display will change to **OSP**.
2. Press the SET key under the HEAT display to begin viewing the current setting. The set point may be changed with a screwdriver and the display will update accordingly.
3. When setting and/or viewing is complete, the POWER key can be pressed to return to the previous menu.

Temperature Probe Calibration - CAL

This section applies only to the calibration of the temperature probe system. The hot plate surface and the motor speed cannot be calibrated. This method is only applicable to units that have heating functionality.

There are two types of calibration available. The choice of which calibration to choose will depend on the equipment that is available. Calibration for either method is done at a single user selectable temperature. Therefore the calibration will be most accurate at that temperature. Note: The unit has not been calibrated at any temperature from the factory. If you wish to have your SUPER-NUOVA Multi-Place plate calibrated at the factory, contact customer service at 1-800-553-0039 for further information.

The first and preferred method of calibration is **Oil**, also known as Oil Bath Method. It is preferred due to the relative ease and speed at which the procedure can be performed. This method will require the customer to have a precision bath with temperature readout. The bath could be oil, water, salt, or other fluid or material as long as the temperature is stable and the readout is accurate. A thermocouple simulator may also be used, but this will not correct for error in the probe.

The second type of calibration is **SyS**, also known as System Calibration. This method can be used when an independent temperature source such as a bath is not available. The hot plate itself is used to supply the bath. Although an independent and accurate method of determining temperature is still required. This measuring system could be as simple as an accurate thermometer. See the "Accessories" section for N.I.S.T. traceable thermometers available from Thermo Scientific. The bath chosen should be as similar to the user's typical load as possible. For example, if the load is 150ml of aqueous solution in a 500ml Erlenmeyer flask, then the load during calibration should be the same.

Oil Bath Method of Calibration

1. With the probe connected to the unit, insert the probe connected to the unit to be calibrated into a bath that has stabilized at the desired calibration temperature. Allow sufficient time for the probe to stabilize.
2. Plug the unit into the appropriate power, but do not turn it on (displays should be blank, unless Hot Top Warning System is indicating a hot surface), enter the Service Menu by pressing and holding the POWER key. After about 3 seconds a single beep will be heard and you may remove your finger from the POWER key. The display will change to **OSP**.
3. Rotate the center knob dial one position clockwise and the display will read **CAL**. This is the calibration menu. Press the SET key under the HEAT display. The display will now read **Oil**. Press the SET key under the HEAT display again to accept, and the display will change to no. Rotate the center knob one position to change the display to **yES** and press the SET key under the HEAT display again.
4. The HEAT display will show the temperature that is currently measured at the probe. If the display shows “---” then the probe is not connected to the unit and must be connected before continuing. The SET indicator under the HEAT display will be flashing to let the user know that the display is ready to be adjusted using the center knob.
5. Adjust the HEAT display using the center knob until it matches the independent probe. When this is complete, press the SET key under the HEAT display. The unit will turn OFF automatically. Calibration of the probe system is now complete.

System Method of Calibration

1. Select an independent temperature probe to be placed in the load, along with the unit temperature probe before continuing with calibration. Select the load to be calibrated, and place on top of the hot plate. Place a stir bar in the mixture if stirring is desired and available on the unit being calibrated. Make sure to have probe plugged into the unit and placed in the load. Also ensure that the OTP adjustment on the front edge of the unit is set high enough to allow the load to achieve the calibration temperature.
2. With the unit plugged into the appropriate power, but not turned on yet (displays should be blank, unless the Hot Top Warning System is indicating a hot surface), enter the Service Menu by pressing and holding the POWER key. After about 3 seconds a single beep will be heard and you may remove your finger from the POWER key. The display will change to **OSP**.
3. Rotate the center knob dial one position clockwise and the display will read **CAL**. This is the calibration menu. Press the SET key under the HEAT display. The display will now read **Oil**. Rotate the center knob one position and the display will read **SyS**. Press the SET key under the HEAT display again to accept, and the display will change to no. Rotate the center knob one position to change the display to **yES** and press the SET key under the HEAT display again.
4. The SET indicator under the HEAT display will be lit, and the displays will show the temperature at which the unit was last calibrated. The calibration temperature may be adjusted by using the center knob. Temperature can only be selected in whole degrees Celsius. The adjustable range is 1 – 370°C. When the adjustment is completed, press the SET key under the HEAT display to approve the selection.

5. If the unit undergoing calibration does not have stirring capability then skip to the next step. The SET indicator under the STIR display will be lit, and the displays will show the stirring control set point. The speed may be adjusted by using the center knob. The adjustable range is 50 – 999, and also OFF (zero). When the adjustment is completed, press the SET key under the STIR display to approve the selection.
6. The HEAT display will now show the temperature that is currently measured at the probe. If the display shows “---” then the probe is not connected to the unit and must be connected before continuing. The unit will begin heating to the setpoint. The HEAT and STIR displays will flash until the temperature is within $\pm 2^{\circ}\text{C}$ of the chosen setpoint.
7. Once the temperature is within $\pm 2^{\circ}\text{C}$ of the set point, a beep will sound and the SET indicator under the HEAT display will begin flashing to let the user know that the display is ready to be adjusted using the center knob. Although it may be desirable to wait longer to allow the temperature of the unit and fluid to stabilize further.
8. Adjust the HEAT display using the center knob to make it match the independent probe. When this is complete, press the SET key under the HEAT display. The unit will turn OFF automatically. Calibration of the probe system is now complete.

Thermometer Mode - Prb

This option is only available for units with heating functionality. The Thermometer Mode can be used to display temperature using the probe without the heating control on. Stirring can also be independently used if desired .

NOTE: Heating will suspend while in thermometer mode.

To enter Thermometer Mode follow the instructions given below:

1. Plug the unit into the appropriate power, but do not turn it on (displays should be blank, unless Hot Top Warning System is indicating a hot surface), enter the Service Menu by pressing and holding the POWER key. After about 3 seconds a single beep will be heard and you may remove your finger from the POWER key. The display will change to **OSP**.
2. Rotate the center knob until the display reads Prb. Press the SET key under the HEAT display to accept, and the display will change to **OFF**. Rotate the center knob one position to change the display to **On** and press the SET key under the HEAT display again.
3. The unit will re-start and when done initializing, will now be in Thermometer Mode. The SET key under the HEAT display will have no affect while in Thermometer Mode.
4. To return to normal operation, press the POWER key, and the unit will turn OFF. When the unit is turned back ON, it will be back to normal operation.

Timer Shutdown - End

This feature is available for all units, but not all sub-menu options will be applicable. The purpose of this feature is to control what is turned off when the timer elapses. The default is Heating off for hot plates and stir plates, and Stirring off for stirrers.

To modify/view the Timer Shutdown follow the instructions given below:

1. Plug the unit into the appropriate power, but do not turn it ON (displays should be blank, unless Hot Top Warning System is indicating a hot surface), enter the Service Menu by pressing and holding the POWER key. After about 3 seconds a single beep will be heard and you may remove your finger from the POWER key. The display will change to **OSP**.
2. Rotate the center knob until the display reads End. Press the SET key under either display to accept, and the display will change to **H** (Heating off), **H S** (Heating and Stirring Off), or **S** (Stirring Off). Rotate the center knob to change the display to the method of choice and press the SET key under either display again.
3. The unit will return to the previous menu. Select another feature to change, or press the POWER key again to return to the off mode.

Probe Temperature Limit - PL

This feature is available for units with heating functionality and is only applicable when using a probe. The purpose of this feature is to limit the heating set point to 250°C or allow it to be unlimited only when the probe is plugged in. The reason a user may want to limit the set point when using a probe is to protect the Teflon coated probes from the damage of over-heating. If that is not a concern or a different material of probe is chosen, then unlimited is a safe choice.

To modify/view the Probe Temperature Limit follow the instructions given below:

1. Plug the unit into the appropriate power, but do not turn it on (displays should be blank, unless Hot Top Warning System is indicating a hot surface), enter the Service Menu by pressing and holding the POWER key. After about 3 seconds a single beep will be heard and you may remove your finger from the POWER key. The display will change to **OSP**.

2. Rotate the center knob until the display reads PL. Press the SET key under the HEAT display to accept, and the display will change to **250** (250°C limit), or **UL** (unlimited). Rotate the center knob to change the display to the method of choice and press the SET key under the HEAT display again.
3. The unit will return to the previous menu. Select another feature to change, or press the POWER key again to return to the off mode.

Probe Response - Pr

This feature is available for units with heating functionality and is only applicable when using a probe. The purpose of this feature is to select the minimum time required for a temperature change to be detected before signaling a Probe Out of Solution error (E03). A choice between 9 and 20 minutes in 1 minute increments is possible. The default is 9 minutes, but if a large load is placed on the top, the time may need to be extended to avoid nuisance E03 errors.

To modify/view the Probe Response follow the instructions given below:

1. Plug the unit into the appropriate power, but do not turn it on (displays should be blank, unless Hot Top Warning System is indicating a hot surface), enter the Service Menu by pressing and holding the POWER key. After about 3 seconds a single beep will be heard and you may remove your finger from the POWER key. The display will change to **OSP**.
2. Rotate the center knob until the display reads Pr. Press the SET key under the HEAT display to accept, and the display will change to the current time chosen. Rotate the center knob to change the display and press the SET key under the HEAT display again.
3. The unit will return to the previous menu. Select another feature to change, or press the POWER key again to return to the off mode.

Set Point Limit - SL

This feature is available for units with heating functionality. The purpose of this feature is to select whether the maximum set point will be limited based on the Over-temperature Set Point (**OSP**), or unlimited (**UL**). If it is limited by OSP then the maximum set point that can be chosen will be based on the setting of the OTP control on the front edge of the unit. If a heating set point of 250°C is desired, the OTP must be set at least 50°C higher. Therefore the OSP setting would need to be at least 300°C. The probe circuit is also affected by the selection of OSP. Selection of UL would allow the set point to be unlimited and would not be affected by OSP setting.

To modify/view the Set Point Limit follow the instructions given below:

1. Plug the unit into the appropriate power, but do not turn it on (displays should be blank, unless Hot Top Warning System is indicating a hot surface), enter the Service Menu by pressing and holding the POWER key. After about 3 seconds a single beep will be heard and you may remove your finger from the POWER key. The display will change to **OSP**.
2. Rotate the center knob until the display reads **SL**. Press the SET key under the HEAT display to accept, and the display will change to either **OSP** or **UL**. Rotate the center knob to change the display and press the SET key under the HEAT display again.
3. The unit will return to the previous menu. Select another feature to change, or press the POWER key again to return to the off mode.

Error Disable - Err

The purpose of this feature is to enable or disable a particular error from being detected and displayed. All errors except E12 (locked rotor – stirring control) are able to be disabled. A general option is also available to re-enable all errors at once. When disabling errors though they must be done one at a time.

To modify/view the Error Disable menu follow the instructions given below:

1. Plug the unit into the appropriate power, but do not turn it on (displays should be blank, unless Hot Top Warning System is indicating a hot surface), enter the Service Menu by pressing and holding the POWER key. After about 3 seconds a single beep will be heard and you may remove your finger from the POWER key. The display will change to **OSP**.
2. Rotate the center knob until the display reads Err. Press the SET key under either display to accept, and the display will change to **CLr** (re-enable all disabled errors). Rotate the center knob to change the display to the error number of choice and press the SET key under either display again.
3. The display will now indicate either **On** (the error detection is enabled), or **OFF** (the error detection is disabled). Rotate the center knob to change the display if desired and press the SET key under either display.
4. The unit will return to the previous menu. Select another error to change, or press the POWER key to return to the root Service Menu. Pressing the POWER key one more time will turn the unit off.

Factory Defaults - deF

This feature is available for all units and is designed to restore the control to the default factory settings. **NOTE:** The Model Selection feature will need to be re-visited after resetting the factory defaults (see Model Selection).

To reset to the Factory Defaults follow the instructions given below:

1. Plug the unit into the appropriate power, but do not turn it on (displays should be blank, unless Hot Top Warning System is indicating a hot surface), enter the Service Menu by pressing and holding the POWER key. After about 3 seconds

a single beep will be heard and you may remove your finger from the POWER key. The display will change to **OSP**.

2. Rotate the center knob until the display reads **dEF**. Press either SET key to accept, and the display will change to no. Rotate the center knob to change the display to **yES** and press either SET key.
3. The unit has now been returned to the factory default settings. The unit will return to the previous menu. Select another feature to change, or press the POWER key again to return to the off mode.

Model Selection - SEL

This feature is available for all units to select the type and size, but should only be used by the factory.

To modify/view the Model Selection follow the instructions given below:

1. Plug the unit into the appropriate power, but do not turn it on (displays should be blank, unless Hot Top Warning System is indicating a hot surface), enter the Service Menu by pressing and holding the POWER key. After about 3 seconds a single beep will be heard and you may remove your finger from the POWER key. The display will change to **OSP**.
2. Rotate the center knob until the display reads **SEL**. Press the SET key under either display to accept, and the display will change to **SP** (Stir Plate), or **S** (Stirrer). Rotate the center knob to change the display to the type of unit required and press the SET key under either display again.
3. The unit will return to the root Service Menu. Select another feature to change, or press the POWER key again to return to the off mode.

Flash Upgrade - FLS

This feature is available for all units and is designed to allow a firmware upgrade via RS232 port to be applied without exchanging controls. NOTE: Special software and an RS232 cable are required to complete this procedure. Complete instruction will be included with the firmware upgrade.

General Cleaning Instructions

Keep top surface clean. Use a non-abrasive cleaner. Alkali spills, hydrofluoric acid spills or phosphoric acid spills may damage top and lead to thermal failure. Unplug unit and remove spills promptly. Do not immerse unit for cleaning. Wipe exterior housing with lightly dampened cloth containing mild soap solution.

Troubleshooting

Error Codes

Displayed Message	Intended to Detect	Cause	Solution
E01	Internal thermocouple out of range.	Internal thermocouple not connected. Thermocouple open. Thermocouple connected backwards (reversed polarity).	Ensure proper connection and polarity of thermocouple. Replace thermocouple (attached to element). Ensure proper connection and polarity of thermocouple.
E02	Excessive top heat-up time.	Internal thermocouple short circuit. Failure in Internal thermocouple. Failure in Element. Failure in optocoupler/ triac circuit.	Remove short. Replace thermocouple (attached to element). Replace Element. Replace Control Board.
E03	External Probe left out of solution.	External Probe left out of solution. OTP potentiometer set too low. User selected timeout (Probe Response) too short for current load. External probe connected backwards.	Place external probe into solution. Increase OTP setting. Increase external probe timeout (Probe Response). Correct orientation of external probe.
E04	OTP thermocouple out of range.	OTP Circuit failure.	Replace Control Board.
E05	OTP potentiometer out of range.	OTP Circuit failure.	Replace Control Board.
E06	OTP detected over temperature condition, relay has opened, power to the element removed.	OTP thermocouple temperature is above the OTP potentiometer setting. OTP thermocouple temperature is above the OTP potentiometer setting. OTP thermocouple not connected.	Increase OTP potentiometer setting. Reduce Hotplate set point. Ensure proper connection and polarity of OTP thermocouple.
E07	Large difference between Internal thermocouple and OTP thermocouple.	Internal or OTP thermocouple not connected. Internal or OTP thermocouple short circuit. Internal or OTP thermocouple connected backwards (reversed polarity).	Ensure proper connection and polarity of affected thermocouple. Remove short of affected thermocouple. Ensure proper connection and polarity of affected thermocouple.

TROUBLESHOOTING

Displayed Message	Intended to Detect	Cause	Solution
E11	AC power not properly detected.	Failure in AC power detection (zero cross) circuit.	Replace Control Board.
E12	Locked rotor in stirring control.	Locked rotor condition. Failure in motor. Failure in motor optocoupler / triac circuit. Failure in motor optical encoder/ encoder wheel.	Free locked rotor. Replace motor. Replace Control Board. Replace motor optical encoder.
E13	Program checksum	Memory failure.	Replace Control Board. Reprogram Control Board.
E21	Corrupted data flash memory.	Checksum failure during data flash recovery.	See below.*

Errors E01 through E07 are heating errors. Error Handler will lock out heating functions if heating error is detected. Stirring functionality is unaffected. If the condition that caused the error is no longer present, pressing the POWER button or unplugging the unit will clear Errors E01-E07.

Errors E11 and E12 are stirring errors. Error Handler will lock out stirring functions if stirring error is detected. Heating functionality is unaffected. Pressing the POWER button or unplugging the unit will clear Error E12. Unplugging the unit will clear Error E11.

*Error 21 is a data flash memory error. Data flash memory will be automatically re-initialized. Action needed for this error is the following:

- Re-enter custom settings for preset A, preset B and preset C as the unit has been reset to factory defaults.

Exploded Views

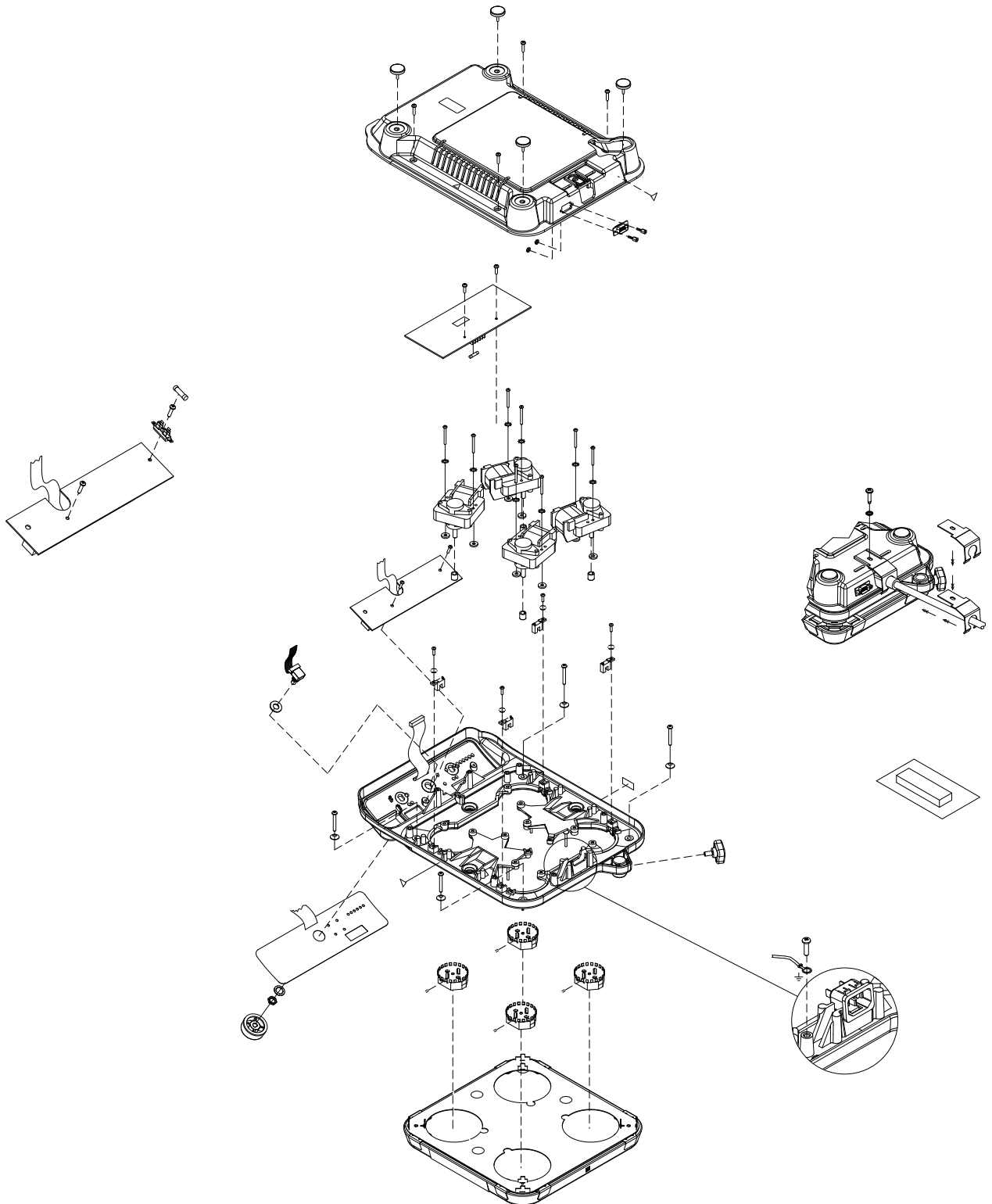

Multi-Place Stirrer – Exploded View

EXPLODED VIEWS

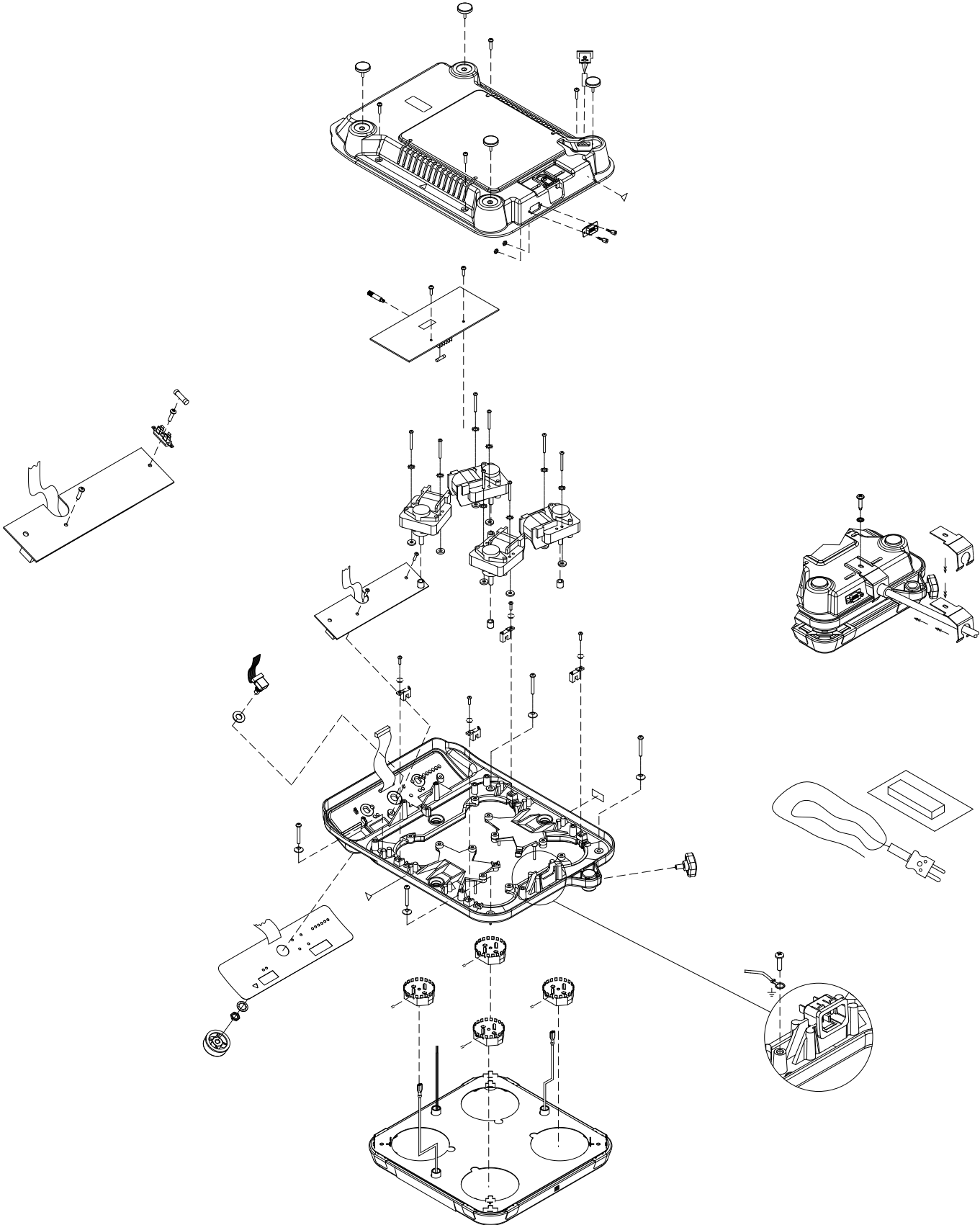

Multi-Place Stirring Hot Plate – Exploded View

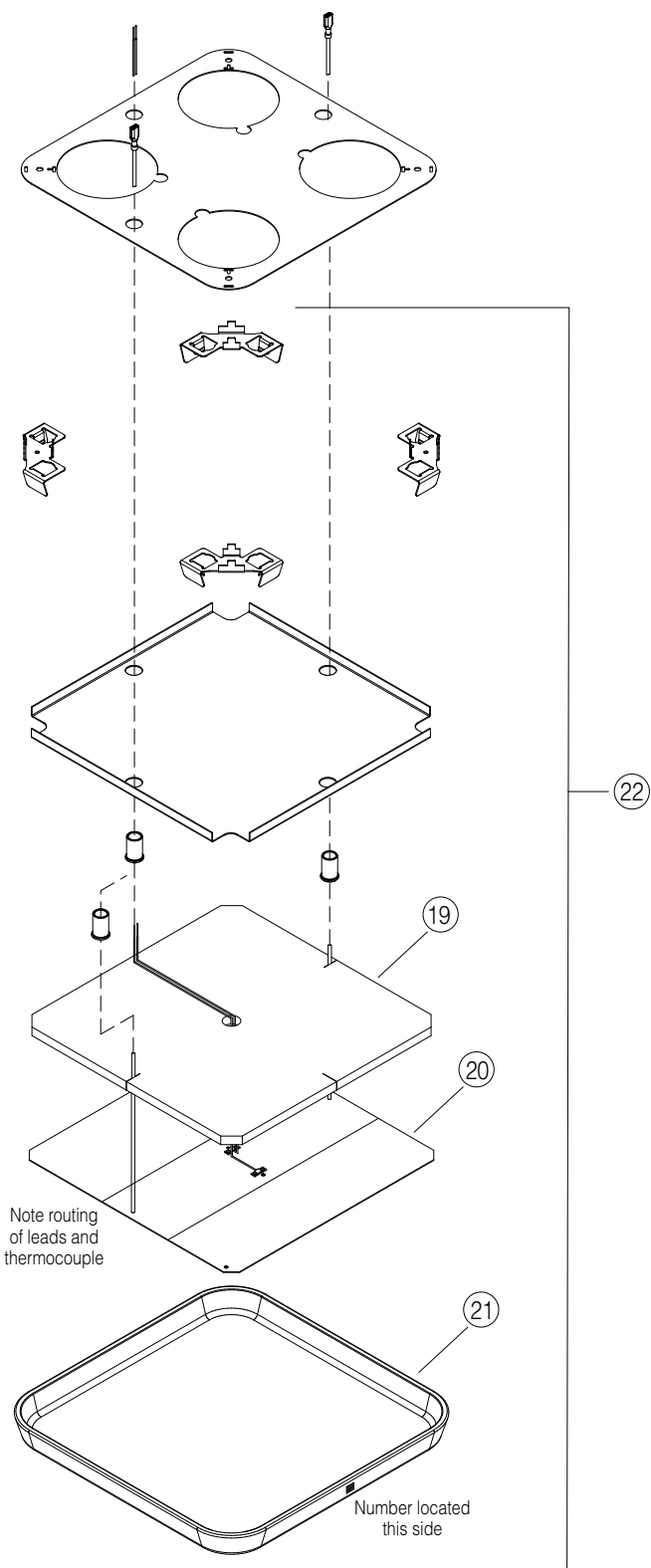

Multi-Place Stirring Hot Plate - Top Assembly

EXPLODED VIEWS

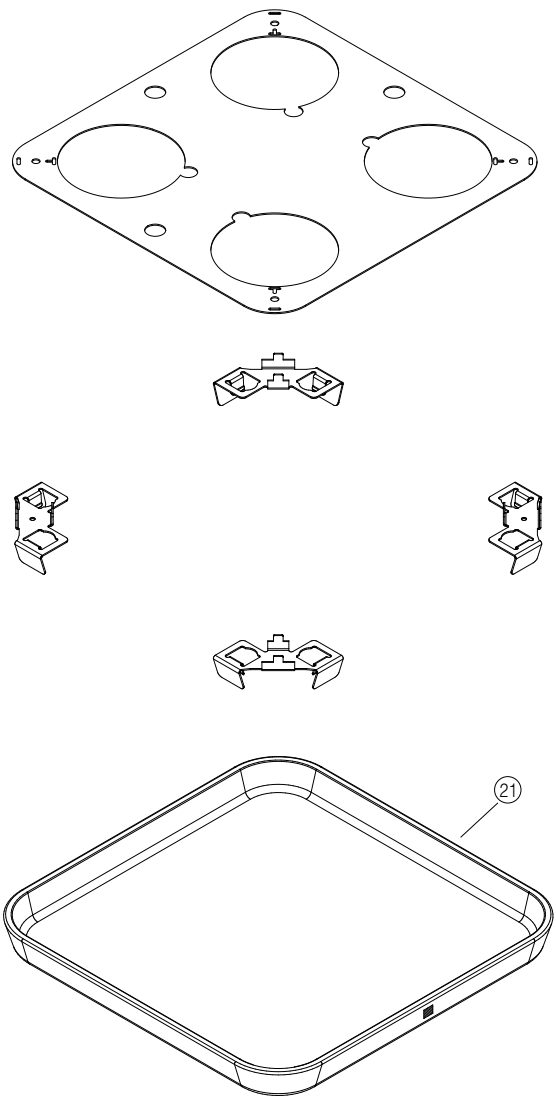

Multi-Place Stirrer - Top Assembly

Wiring Diagrams

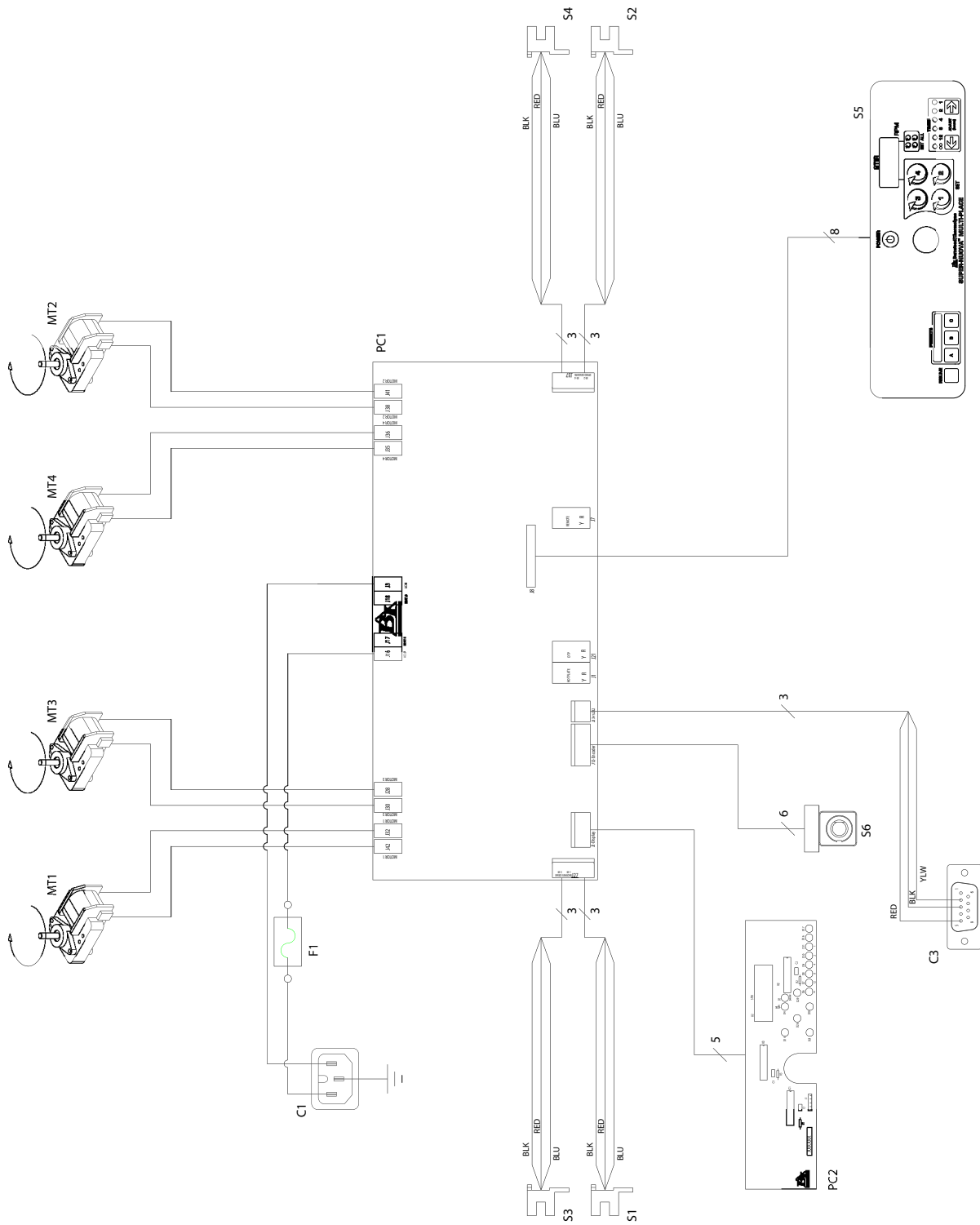

Multi-Place Stirrer - Wiring Diagram

WIRING DIAGRAM

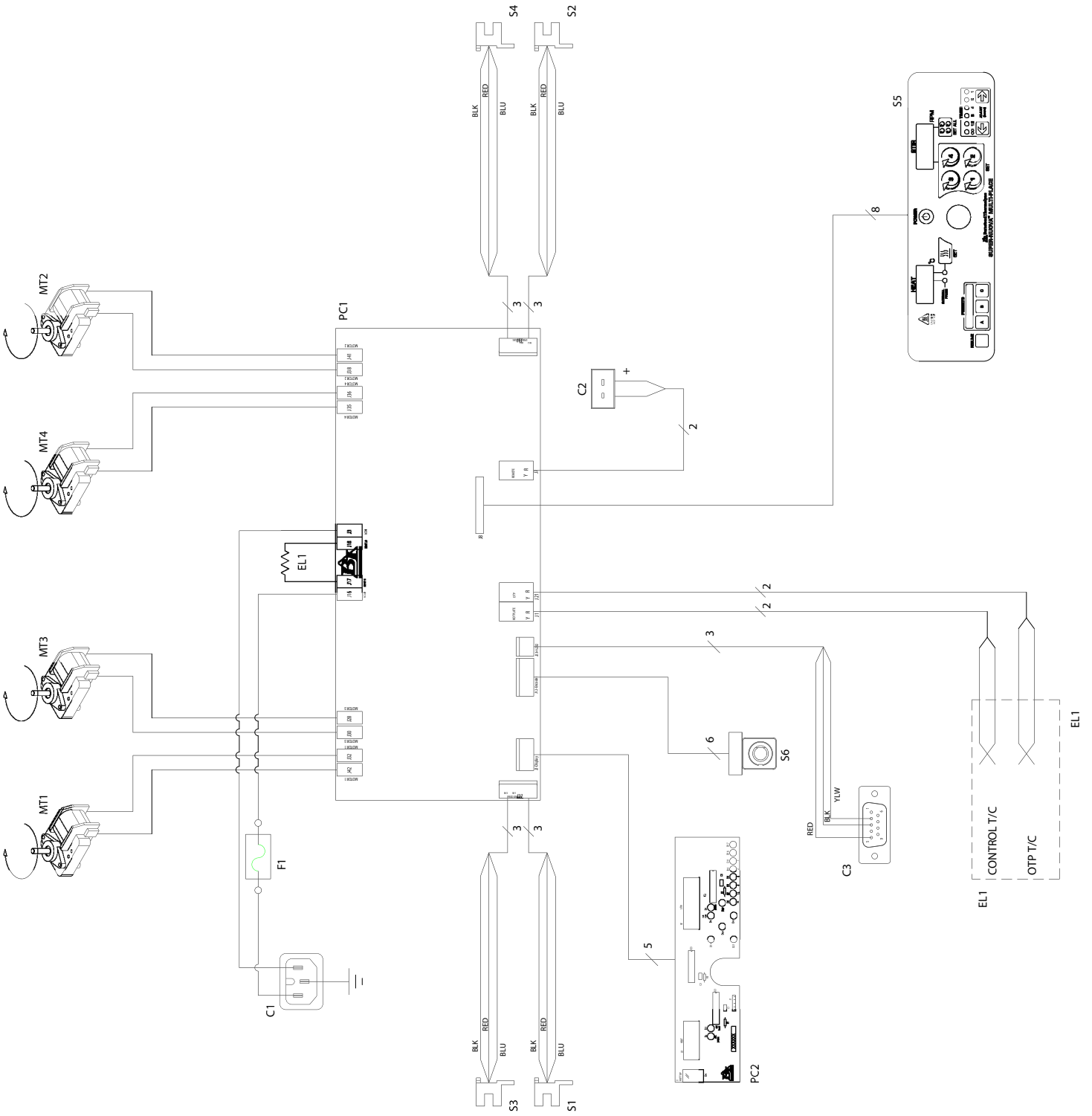

Multi-Place Stirring Hot Plate - Wiring Diagram

Replacement Parts List

To insure your safety and for proper operation, the ceramic top plates for hot plates and stir plates are only sold as complete assemblies. This assembly includes the ceramic top, element, thermocouple, insulation, baffle plate, and 2 ceramic top holders. **We recommend not replacing individual components of the top plate.**

Key	Stirrer Part No.	Stirring Hot Plate Part No.	Description
1	261575	261575	PC Board Fuse - 220-240V
2	FTX34	FTX34	Foot (4)
3	PC1360X2	PC1359X3	Control Board - 120V
3	PC1360X3	PC1359X4	Control Board - 220-240V
4	266058	266058	PC Board Fuse - 120V
4	261575	261575	PC Board Fuse - 220-240V
5	PC1360X1	PC1359X2	Display Board
6	SWX217	SWX217	Encoder
7	SWX223	SWX222	Membrane Switch
8	KBX105	KBX105	Knob
9	MG1359X2	MG1359X2	Magnet
10	CEX373	CEX373	Power Entry Module
11	SC1313X1	SC1313X1	Speed Sensor (long)
12	SC1310X1	SC1310X1	Speed Sensor (short)
13	CRX106	CRX106	Cord Set - 120V
13	CRX104	CRX104	Cord Set - 220-240V
14	KBX106	KBX106	Knob
15	ZSX65A	ZSX65A	Stir Bar
16	MT1359X1	MT1359X1	Motor - 120V
16	MT1359X2	MT1359X2	Motor - 220-240V
17	MT1313X3	MT1313X3	Motor - 120V (short leads)
17	MT1313X4	MT1313X4	Motor - 220-240V (short leads)
18	BC1313X1	BC1313X1	Retaining Clip - 120V
18	BC1313X2	BC1313X2	Retaining Clip - 220-240V
19	--	JNX38	Upper Insulation
20	--	ELX53	Heating Element - 120V - w/thermocouple
20	--	ELX55	Heating Element - 220-240V - w/thermocouple
21	PT1359X3	PT1359X3	Ceramic Top
22	--	EL1359X1	Hot Plate Top Assembly - 120V
22	--	EL1359X3	Hot Plate Top Assembly - 220-240V
23	--	TCX16	6" Chemically resistant stainless steel probe with 8" PFA encapsulation, LSA Type K

Accessories

Part No.	Description
TC732X1	General purpose immersion probe with 6" (15.24 cm) stainless steel sheath
TC732X2	General purpose immersion probe with 10" (25.40 cm) stainless steel sheath
TC727X2	Chemically-resistant immersion probe with 7" (17.78 cm) Teflon sheath
711S	Non-Mercury Thermometer 20 to 100°C Range - 76 mm immersion
647-1S	Non-Mercury Thermometer 0 to 110°C Range - 35 mm immersion
1007-3BLS	Non-Mercury Thermometer -1 to 201°C Range - 76 mm immersion
615-3SC	Mercury Teflon Coated Thermometer -10 to 200°C Range - 76 mm immersion
260CW-3BLS	Non-Mercury Thermometer -10°C to 260°C Range - 76 mm immersion
ERT605	Waterproof Digital Thermometer -50 to 280°C
7077	Thermometer Clamp
7068	90° Clamp Holder
1000-2	12" Aluminum Rod
7078	Large Clamp
7079	Small Clamp (up to 1/2")
WHX18	RS232 cable

NOTE: Thermometers are N.I.S.T. traceable, however, they do not come with N.I.S.T. certificates. To obtain a certificate before ordering, call Customer Service at 1-800-553-0039.

Ordering Procedures

Please refer to the Specification Plate for the complete model number, serial number, and series number when requesting service, replacement parts or in any correspondence concerning this unit.

All parts listed herein may be ordered from the **Thermo Scientific** dealer from whom you purchased this unit or can be obtained promptly from the factory. When service or replacement parts are needed we ask that you check first with your dealer. If the dealer cannot handle your request, then contact our Customer Service Department at 563-556-2241 or 800-553-0039.

Prior to returning any materials, please contact our Customer Service Department for a "Return Materials Authorization" number (RMA). Material returned without an RMA number will be refused.

Two Year Limited Warranty

This Thermo Scientific product is warranted to be free of defects in materials and workmanship for two (2) years from the first to occur of (i) the date the product is sold by the manufacturer or (ii) the date the product is purchased by the original retail customer (the "Commencement Date"). Except as expressly stated above, the MANUFACTURER MAKES NO OTHER WARRANTY, EXPRESSED OR IMPLIED, WITH RESPECT TO THE PRODUCTS AND EXPRESSLY DISCLAIMS ANY AND ALL WARRANTIES, INCLUDING BUT NOT LIMITED TO, WARRANTIES OF DESIGN, MERCHANT ABILITY AND FITNESS FOR A PARTICULAR PURPOSE.

An authorized representative of the manufacturer must perform all warranty inspections. In the event of a defect covered by the warranty, we shall, as our sole obligation and exclusive remedy, provide free replacement parts to remedy the defective product. In addition, for products sold within the continental United States or Canada, the manufacturer shall provide free labor to repair the products with the replacement parts, but only for a period of ninety (90) days from the Commencement Date.

The warranty provided hereunder shall be null and void and without further force or effect if there is any (i) repair made to the product by a party other than the manufacturer or its duly authorized service representative, (ii) misuse (including use inconsistent with written operating instructions for the product), mishandling, contamination, overheating, modification or alteration of the product by any customer or third party or (iii) use of replacement parts that are obtained from a party who is not an authorized dealer of Thermo Scientific products.

Heating elements, because of their susceptibility to overheating and contamination, must be returned to the factory and if, upon inspection, it is concluded that failure is due to factors other than excessive high temperature or contamination, the manufacturer will provide warranty replacement. As a condition to the return of any product, or any constituent part thereof, to the factory, it shall be sent prepaid and a prior written authorization from the manufacturer assigning a Return Materials Number to the product or part shall be obtained.

IN NO EVENT SHALL THE MANUFACTURER BE LIABLE TO ANY PARTY FOR ANY DIRECT, INDIRECT, SPECIAL, INCIDENTAL, OR CONSEQUENTIAL DAMAGES, OR FOR ANY DAMAGES RESULTING FROM LOSS OF USE OR PROFITS, ANTICIPATED OR OTHERWISE, ARISING OUT OF OR IN CONNECTION WITH THE SALE, USE OR PERFORMANCE OF ANY PRODUCTS, WHETHER SUCH CLAIM IS BASED ON CONTRACT, TORT (INCLUDING NEGLIGENCE), ANY THEORY OF STRICT LIABILITY OR REGULATORY ACTION.

For the name of the authorized Thermo Scientific product dealer nearest you or any additional information, contact us:

2555 Kerper Blvd., Dubuque, Iowa, 52004-0797

Phone: 563-556-2241 or 1-800-553-0039

Fax: 563-589-0516

Web: www.thermo.com