



Your **definitive** source  
for quality pre-owned  
equipment.

**Artisan Technology Group**

(217) 352-9330 | [sales@artisanng.com](mailto:sales@artisanng.com) | [artisanng.com](http://artisanng.com)

**Full-service, independent repair center**

with experienced engineers and technicians on staff.

**We buy your excess, underutilized, and idle equipment**

along with credit for buybacks and trade-ins.

**Custom engineering**

so your equipment works exactly as you specify.

- Critical and expedited services
- In stock / Ready-to-ship
- Leasing / Rentals / Demos
- ITAR-certified secure asset solutions

**Expert team | Trust guarantee | 100% satisfaction**

All trademarks, brand names, and brands appearing herein are the property of their respective owners.

Find the VWR 1575 at our website: [Click HERE](#)

# VWR ™ INTERNATIONAL



INCUBATORS  
MODELS: 1575, 1575R  
ORBITAL SHAKING INCUBATOR  
INSTALLATION AND OPERATION MANUAL

These units are general purpose incubators for professional, industrial or educational use where the preparation or testing of materials is done at approximately atmospheric pressure and no flammable, volatile or combustible materials are being heated. These units are not intended for hazardous or household locations or use.

**Sheldon Manufacturing Inc.**

P.O. Box 627

Cornelius, Oregon 97113

EMAIL: [tech@Shellab.com](mailto:tech@Shellab.com)

INTERNET: <http://www.Shellab.com>

PHONE: 1-800-322-4897, (503) 640-3000

FAX: (503) 640-1366

# TABLE OF CONTENTS

INTRODUCTION.....	6
General Safety Considerations .....	6
RECEIVING YOUR UNIT.....	7
Inspection Guidelines.....	7
Accessories.....	7
Returning Shipment .....	7
Recording Data Plate Information.....	8
GRAPHIC SYMBOLS .....	9
CONTROL PANEL OVERVIEW .....	10
Power Switch .....	10
Main Temperature Control .....	10
Heating Lamp.....	10
Overtemperature Thermostat.....	10
Safety Lamp .....	11
Shaker Switch .....	11
Oscillation Controller .....	11
Auxiliary Control Panel.....	11
Light.....	12
ACCY.....	12
INSTALLATION.....	13
Location.....	13
Lifting and Handling .....	13
Leveling.....	14
Power Source.....	14
Cleaning .....	14
OPERATION .....	15
Turning On the Unit.....	15
Installing the Sample Tray .....	15
Setting the Main Temperature Control.....	15
Calibrating the Main Temperature Control.....	16
Setting the Overtemperature Thermostat .....	16
Setting the Oscillation Control.....	16
Setting the Oscillation Stroke.....	17
Setting the Counterbalance .....	17
Interior Accessory Outlet.....	21
MAINTENANCE .....	22
Cleaning .....	22
Disinfecting.....	22
Controls .....	22
TROUBLESHOOTING .....	23
PARTS LIST.....	29

UNIT SPECIFICATIONS.....	31
SCHEMATICS.....	33

## FIGURES

Figure 1. Control Panel .....	10
Figure 2. Auxiliary Control Panel .....	11
Figure 3. Setup for ½ Inch Stroke .....	18
Figure 4. Setup for ¾ Inch Stroke .....	19
Figure 5. Setup for 1 Inch Stroke .....	20
Figure 6. Wire Diagram .....	33

## TABLES

Table 1. Data Plate Information .....	8
Table 2. Symbols .....	9
Table 3. Counterbalance Starting Locations.....	17
Table 4. Temperature Troubleshooting.....	23
Table 5. Refrigeration Troubleshooting (R Suffix Models Only) .....	26
Table 6. Mechanical Troubleshooting .....	27
Table 7. Miscellaneous Troubleshooting .....	28
Table 8. Parts .....	29
Table 9. Temperature.....	31
Table 10. Capacity .....	31
Table 11. Dimensions .....	31
Table 12. Shaking Mechanism.....	32
Table 13. Refrigeration.....	32
Table 14. Electrical.....	32

## REVISION HISTORY

Manual	Revision	Updates
4861237V	10-02	Initial release
4861237V	10-04	Additional information and additions.
4861237V	11-05	Additional information and additions.
4861237V	04-07	Spec Sheet Revsion
4861237V	01-08	Updated Wiring Diagram
4861237V	06-08	Updated Parts List Condensing Units

# INTRODUCTION

Thank you for choosing an orbital shaking incubator. These units are not intended for use at hazardous or household locations.

Before you use the unit, read this entire manual carefully to understand how to install, operate, and maintain the unit in a safe manner. Your satisfaction with the unit will be maximized as you read about its safety and operational features.

Keep this manual on-hand so it can be used by all operators of the unit. Be sure all operators of the unit are given appropriate training before you put the unit in service.

---

**Note:** Use the unit only in the way described in this manual. Failure to follow the guidelines and instructions in this manual may be dangerous and illegal.

---

## ***General Safety Considerations***

Your incubator and its recommended accessories have been designed and tested to meet strict safety requirements.

For continued safe operation of your incubator, always follow basic safety precautions including:

- Read this entire manual before using the incubator.
- Be sure you follow any city, county, or other ordinances in your area regarding the use of this unit.
- Use only approved accessories. Do not modify system components. Any alterations or modifications to your incubator may be dangerous and will void your warranty.
- Always plug the unit's power cord into a grounded electrical outlet that conforms to national and local electrical codes. If the unit is not grounded, parts such as knobs and controls may conduct electricity and cause serious injury.
- Do not connect the unit to a power source of any other voltage or frequency beyond the range stated on the data plate at the rear of the unit.
- Do not modify the power cord provided with the unit. If the plug does not fit an outlet, have a proper outlet installed by a qualified electrician.
- Avoid damaging the power cord. Do not bend it excessively, step on it, place heavy objects on it. A damaged cord can easily become a shock or fire hazard. Never use a power cord after it has become damaged.

# RECEIVING YOUR UNIT

Before leaving our factory, all units are packaged in high quality shipping materials designed to provide protection from transportation related damage.

Once a unit leaves our factory, however, safe delivery becomes the responsibility of the carrier who is liable for loss or damage to your unit. Damage sustained during transit is not covered under your unit warranty.

When you receive your unit, inspect it for concealed loss or damage to its interior and exterior. Should you find any damage to the unit, follow the carrier's procedure for claiming damage or loss.

## ***Inspection Guidelines***

Carefully inspect the shipping carton for damage. If the carton is damaged, report the damage to the carrier service that delivered the unit.

If the carton is not damaged, open the carton and remove its contents. Verify that all of the following equipment is included in the crate:

- Two (2) shelves
- Eight (8) shelf clips
- One (1) sample tray
- Six (6) counter weights
- Four (4) leveling feet

## ***Accessories***

Carefully check all packaging before discarding. Save the shipping carton until you are sure everything is in order.

## ***Returning Shipment***

If you must return the unit for any reason, first contact your service representative for authorization. You will be asked to provide the data plate information. See Recording Data Plate Information below.



## ***Recording Data Plate Information***

Once you have determined the unit is free from damage, locate the data plate at the back of the unit. The data plate indicates your unit's model number and serial number. Record this information below for future reference.









**Table 1. Data Plate Information**

<b>Model Number</b>	
<b>Serial Number</b>	
<b>Part Number</b>	
<b>Voltage</b>	

# GRAPHIC SYMBOLS

Your unit is provided with a display of graphic symbols that will help in identifying user adjustable components.

**Table 2. Symbols**

Symbol	Identification
	Indicates that you should consult your operator's manual for further instructions.
	Indicates "Temperature"
	Indicates "Overtemperature Protection"
	Indicates "AC Power"
I	Indicates the power is "ON"
O	Indicates the power is "OFF"
	Indicates "Protective Earthground"
	Indicates "Up" and "Down" respectively
	Indicates "Manually Adjustable"
	Indicates "Potential Shock Hazard" behind partition
	Indicates " <b>Unit should be recycled</b> " (Not disposed of in land-fill)

# CONTROL PANEL OVERVIEW

Figure 1 provides an illustration of the control panel.

Figure 1. Control Panel

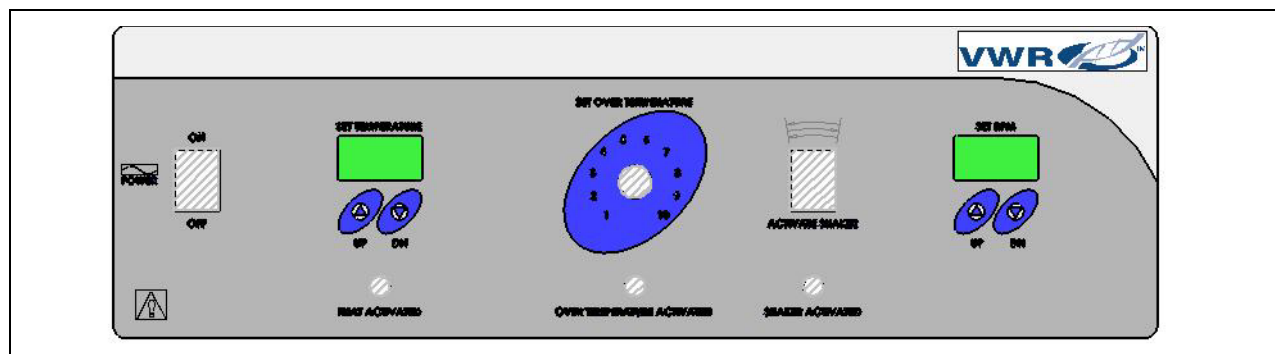

## Power Switch

The main power I/O (on/off) switch controls all power to the unit and must be in the I position before any systems are operational.

## Main Temperature Control

Marked °C, the Main Temperature Control consists of the digital display and Up/Down arrow pads for inputting set point temperature and calibration.

## Heating Lamp

This pilot lamp is ON when the unit is heating up to set point. It is blinking when the controlling temperature is at set point.

## Overtemperature Thermostat

This control is marked SET OVERTEMPERATURE. It is equipped with a graduated dial marked from 0 to 10 and a knob that requires a flat-edged tool for adjusting settings to eliminate accidental changes. Completely independent of the Main Temperature Controller, the Overtemperature Thermostat guards against any Main Temperature Controller failure, which would allow the temperature to rise past the set point. If the temperature rises to the Overtemperature set point, this thermostat takes control of the heating element and allows continued use of the incubator until the problem can be resolved, or service can be arranged.

We do not recommend operating the unit for an extended period of time using only the Overtemperature as the temperature uniformity will be affected.

## ***Safety Lamp***

Located directly below the Overtemperature Thermostat, this pilot lamp comes ON when the Overtemperature Thermostat is activated. During normal operating conditions, this light should never come on.

## ***Shaker Switch***

Located to the right of the Overtemperature Thermostat, this switch engages the oscillation mode of the incubator. To enable oscillation, this switch must be in the I position. This switch does not have to be ON to adjust the oscillation set point.

## ***Oscillation Controller***

This control is labeled RPM and consists of the UP/DOWN arrow pads and a digital display that shows oscillations per minute. This control is adjustable from 20 to 400 RPM.

## ***Auxiliary Control Panel***

The Auxiliary Control Panel is located on the lower right hand side of the unit. See Figure 2.

**Figure 2. Auxiliary Control Panel**

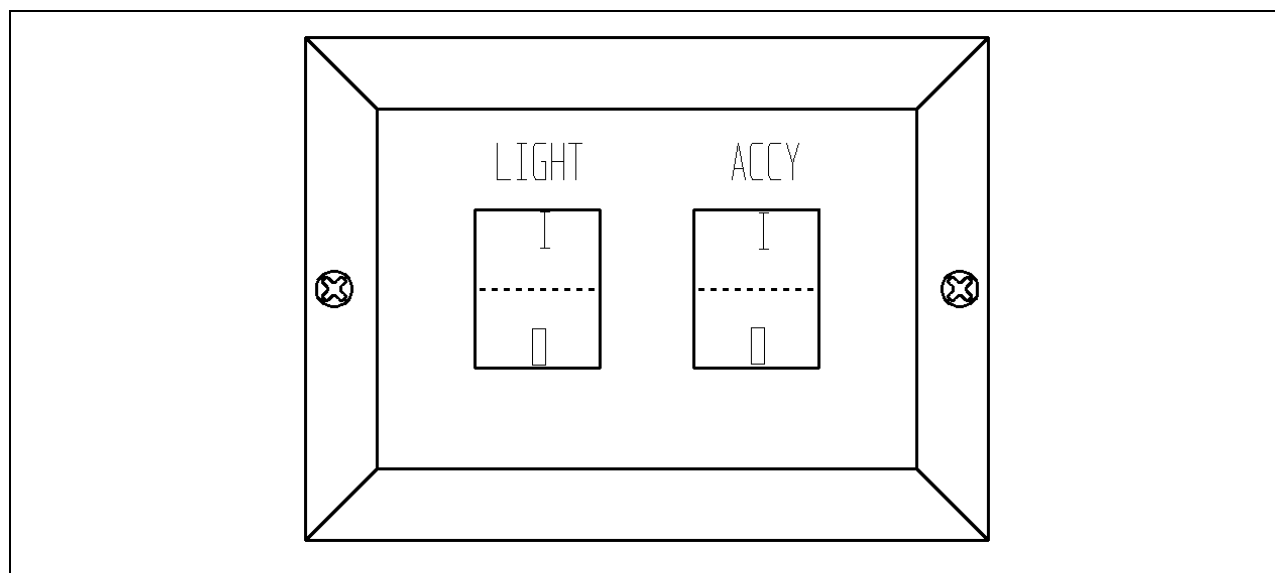

## ***Light***

The light switch controls the internal florescent inspection light.

## ***ACCY***

The ACCY switch controls the internal accessory outlet. See OPERATION for proper wiring and use of this outlet.

# INSTALLATION

This equipment must be used only for its intended application; any alterations or modifications will void your warranty. Local city, county, or other ordinances may govern the use of this equipment. If you have any questions about local requirements, please contact the appropriate local agency. The end user may perform installation.

Under normal circumstances this unit is intended for use indoors, at room temperatures between 5° and 40°C, at no greater than 80% Relative Humidity (at 25°C) and with a supply voltage that does not vary by more than 10%. Customer service should be contacted for operating conditions outside of these limits.

## ***Location***

In selecting a location, consider all conditions that might affect performance, for example:

- Heating/cooling ducts
- Ovens
- Stoves
- Autoclaves
- Direct sun
- Fast moving air currents
- High-traffic areas

Allow a minimum of 20 cm between the unit and walls or partitions that might obstruct free airflow.

## ***Lifting and Handling***

These units are heavy and care should be taken to use appropriate lifting devices that are sufficiently rated for these loads. Follow the guidelines below when lifting and handling the unit.

- Units should be lifted only from their bottom surfaces.
- Doors, handles, and knobs are not adequate for lifting or stabilization.
- The unit should be completely restrained from tipping while lifting or transporting.
- All moving parts, such as shelves and trays, should be removed and doors must be positively locked in the closed position during transfer to prevent shifting and damage.

## ***Leveling***

The unit must sit levelly and solidly. Leveling feet are supplied and must be installed in the four holes in the bottom corners of the unit. Turn the leveling feet counterclockwise to raise the level. Adjust the foot at each corner until the unit stands levelly and solidly without rocking.

---

**Note:** If the unit must be moved, turn the leveling feet all the way clockwise to prevent damage while moving.

---

## ***Power Source***

Check the data plate for voltage and ampere requirements before making a connection. VOLTAGE SHOULD NOT VARY MORE THAN 10% FROM THE DATA PLATE RATING. This unit is intended for 50/60 Hz application. We recommend a separate circuit to prevent loss of product due to overloading or circuit failure.

---

**Note:** Electrical supply to the unit must conform to all national and local electrical codes.

---

## ***Cleaning***

The incubator interior was cleaned at the factory but not sterilized. See MAINTENANCE for cleaning and sterilizing instructions.

# OPERATION

## *Turning On the Unit*

To turn on the unit, perform the following steps:

1. Check the power supply against unit data plate; they must match.
2. Plug the service cord into the grounded electrical outlet. Ensure that the fuse is installed in the power inlet of the unit.
3. Push the power switch to the ON position.
4. Turn the Overtemperature Thermostat to its maximum position, clockwise.

## *Installing the Sample Tray*

To install the sample tray, perform the following steps:

1. Position the front two corners of the sample tray on the shaking mechanism.
2. Set the rest of the tray down
3. All corners of the shaking mechanism should be enclosed within the lips of the sample tray.
4. Shake the tray by its handles to confirm that it is firmly in place.

## *Setting the Main Temperature Control*

To set the main temperature controller, perform the following steps:

1. Enter desired set point temperature. To enter set point mode on the controller, press either the UP or DOWN arrow pad one time.
2. The digital display will start to blink, going from bright to dim. While blinking, the digital display is showing the set point.
3. To change the set point, use the UP and DOWN arrow pads. If the arrow pads are not pressed for five (5) seconds, the display will stop blinking and will read the temperature of the unit.

---

**Note:** The Overtemperature Thermostat at should be turned to its maximum position until the unit has stabilized at desired set point temperature.

---

Allow the incubator at least 24 hours to stabilize.



## ***Calibrating the Main Temperature Control***

We recommend that you calibrate your unit once it has been installed in its working environment and has been stable at the set point for 24 hours. To calibrate the unit, perform the following steps:

1. Place a certified reference thermometer in the chamber by placing it either directly inside or through the access tube at the top left of the unit. Ensure that the thermometer is not touching any shelving. If you place the thermometer directly inside the chamber, taping the thermometer to a Petri dish will raise it off the shelf and keep the scale in view.
2. Allow the temperature to stabilize again until the thermometer reads a constant value for one hour.
3. Compare the digital display with the reference thermometer.
4. If there is an unacceptable difference, put the display into calibration mode by pressing both the Up and Down arrow pads at the same time for approximately five (5) seconds until the display blinks off and on.
5. While blinking, the display can be calibrated by pressing the Up or Down arrow pads until the display reads the correct value.
6. Allow the incubator temperature to stabilize again, and recalibrate if necessary.

## ***Setting the Overtemperature Thermostat***

To set the Overtemperature Thermostat, perform the following steps.

1. Once the incubator is stable at the desired set point, turn the Overtemperature Thermostat counterclockwise until the Overtemperature indicator light turns on.
2. Turn the Overtemperature Thermostat clockwise just the safety indicator light turns off.
3. Continue to turn the Overtemperature Thermostat clockwise an additional two small divisions on its scale past the point where the indicator light went out. This will set the Safety Thermostat at approximately 1°C above the Main Temperature set point.

## ***Setting the Oscillation Control***

To set the oscillation control, perform the following steps:

1. Enter set point mode by pushing and releasing either the UP or DOWN arrow pad one time. The display will start to blink on and off showing the RPM set point.
2. Push the UP or DOWN arrow pad to increase or decrease the RPM set point in increments of 10 RPM. The range for this set point is 30 – 400 RPM.
3. If the arrow pads are not pressed for five (5) seconds the display will stop blinking and revert to displaying the actual RPM.

---

**Note:** For oscillation controls to work as described, the door must be completely closed.

---

## Setting the Oscillation Stroke

To set the oscillation stroke, perform the following steps.

---

**Note:** A 3/16 -inch Allen wrench should be used.

---

1. Assure that the power cord has been disconnected to prevent accidental operation.
2. Remove sample tray.
3. Open the access panel by rotating the wing nut  $\frac{1}{4}$  turn counterclockwise and rotate the counterweight platform until the stroke adjuster appears.
4. Remove the locking bolt and adjust the arm to any of the available options.
5. The dimensions shown are the total stroke of the oscillator, i.e.,  $\frac{1}{2}$  designates a pattern that is +  $\frac{1}{4}$ " from center.

---

**Note:** When the stroke has been changed, counterbalance adjustments may be required.

---

## Setting the Counterbalance

To set the counterbalance, perform the following steps:

1. Assure that the power has been disconnected to prevent accidental operation.
2. Remove the sample tray.
3. Open the access panel and rotate the counterweight platform until the counterweight appears.
4. Remove the wing nuts to adjust the counterweights.

Table 3 shows counterbalance starting locations. For example, 5 kg of sample load being shaken with  $\frac{1}{2}$  inch stroke will require four counterweights attached to the counterbalance platform as shown in Figure 3. Loads should be properly counterbalanced before continuous operation. Unbalanced loading may damage mechanical and electrical operating systems.

**Table 3. Counterbalance Starting Locations**

	No Load	5 kg of samples	10 kg of samples
Counterweights	2	4	6
For $\frac{1}{2}$ " stroke	See Figure 3	See Figure 3	See Figure 3
For $\frac{3}{4}$ " stroke	See Figure 4	See Figure 4	See Figure 4
For 1" stroke	See Figure 5	See Figure 5	See Figure 5

**Note:** Each unit includes six (6) single counterweights when shipped.

Figure 3. Setup for 1/2 Inch Stroke

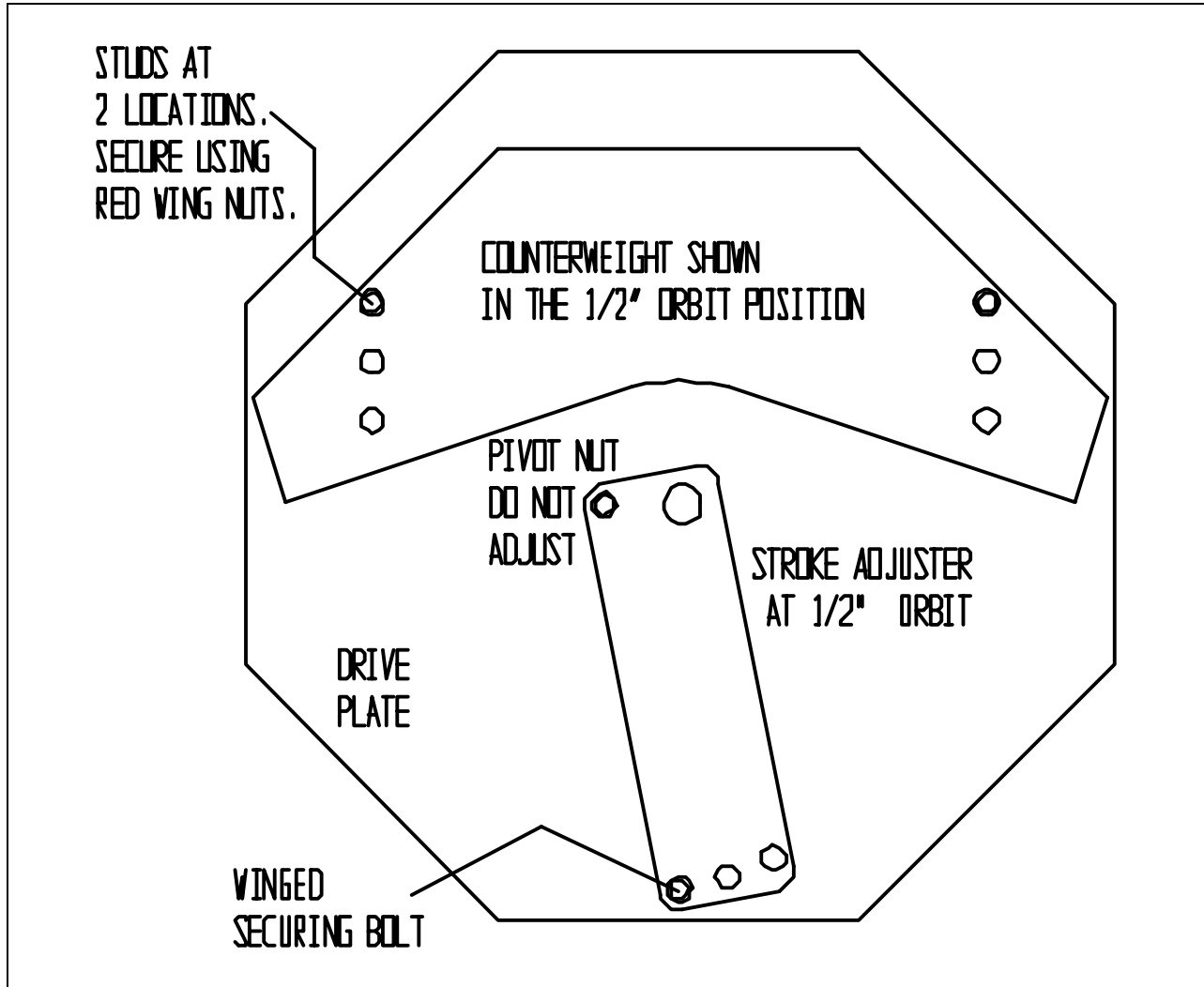

Figure 4. Setup for 3/4 Inch Stroke

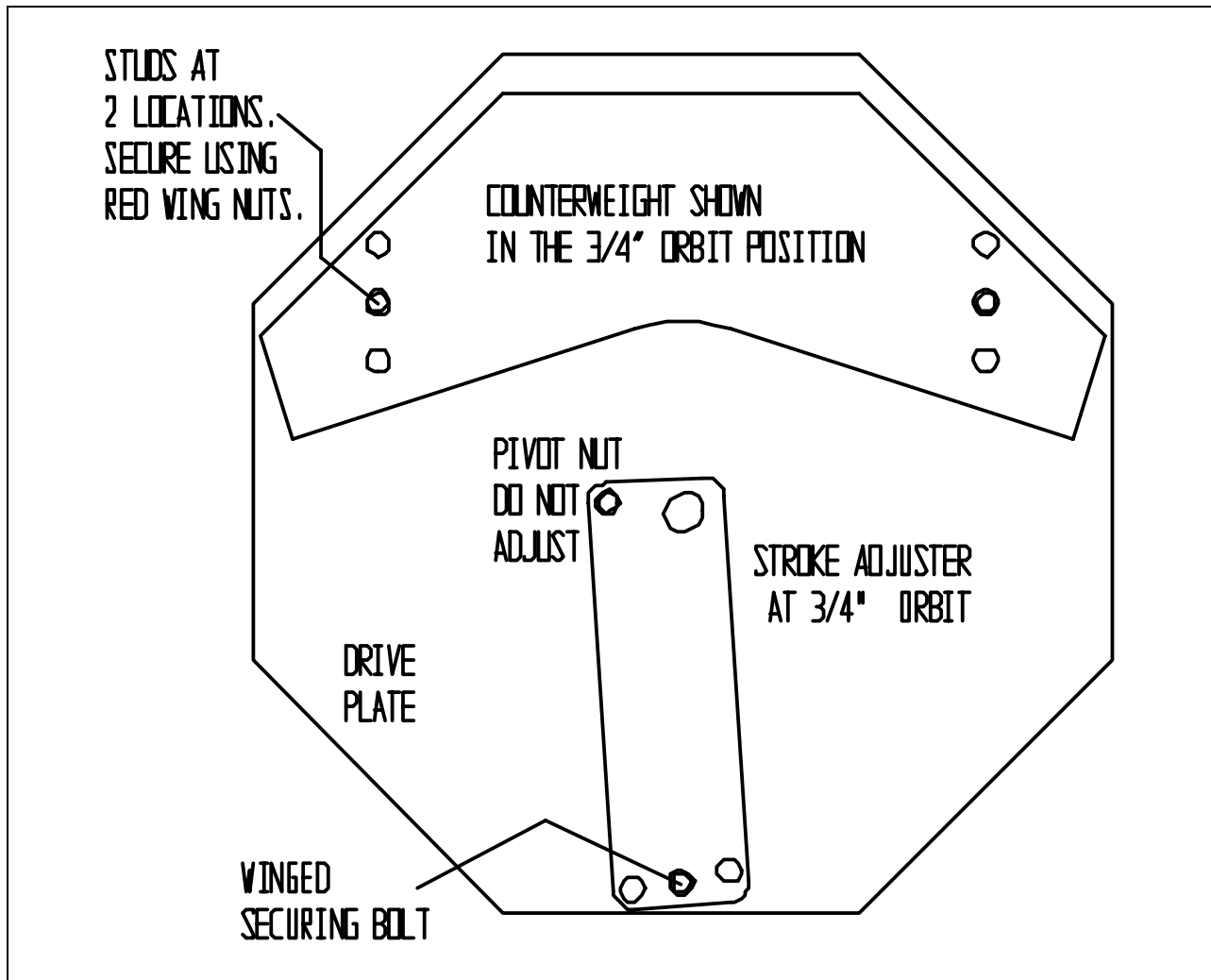
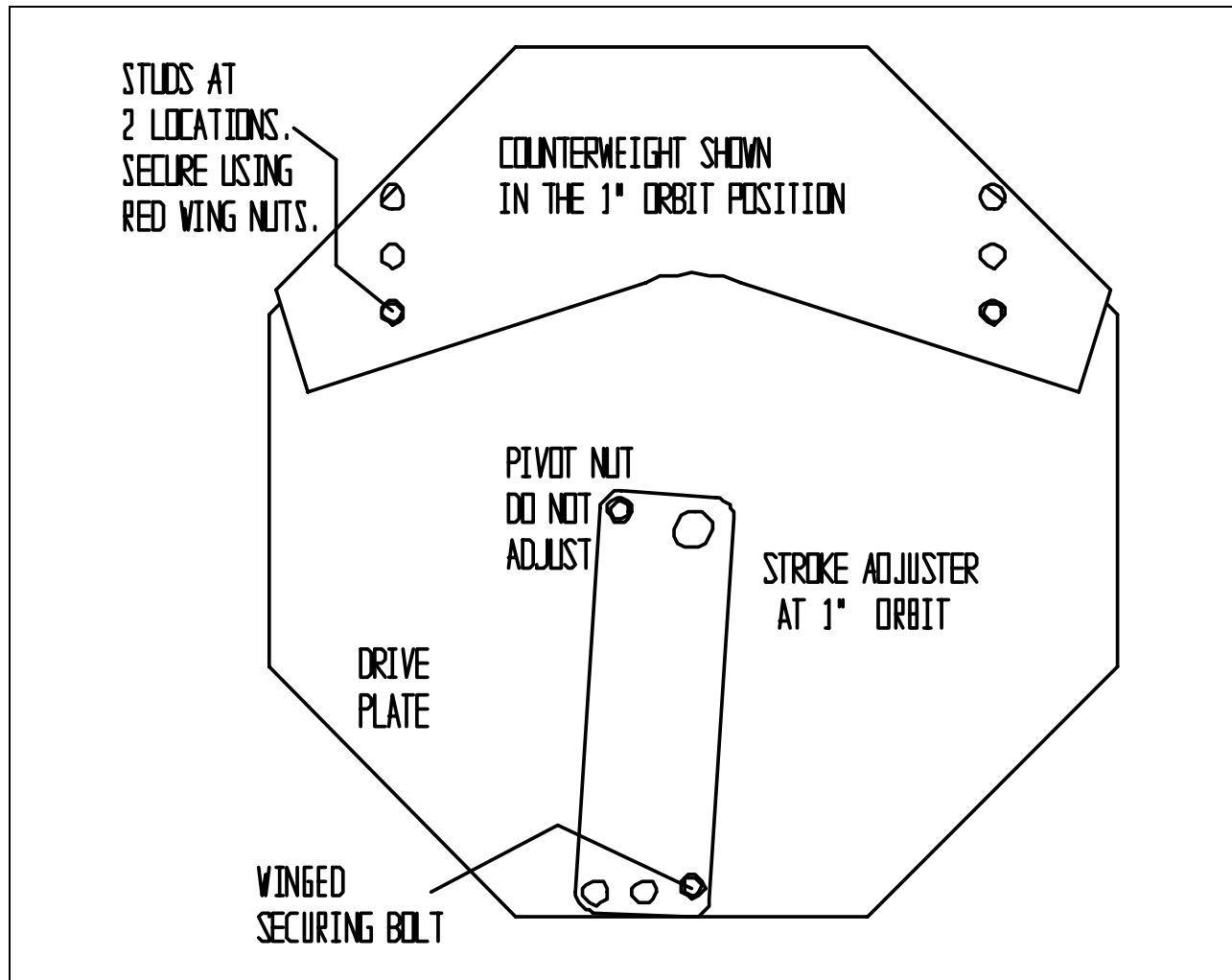

Figure 5. Setup for 1 Inch Stroke



## ***Interior Accessory Outlet***

This unit features an accessory outlet to provide power for equipment such as magnetic stirrers, rockers, etc. The weight of this equipment should not exceed 25 pounds (55.125 kg) per shelf. This equipment may provide additional heat that could affect the temperature range of this incubator. We recommend testing the incubator and any accessory equipment to ensure that the desired operating conditions can be met.

---

**Caution:** This incubator operates at conditions that might damage accessory equipment. Verify that your accessory equipment is capable of operating under the same conditions as the incubator.

---

The outlet is located inside the incubator in the upper right rear of the chamber. The voltage available at the accessory outlet is the SAME as the voltage supplied to the incubator. For example, a 120-vac incubator will have 120 vac at the accessory outlet, and a 240-vac incubator will have 240 vac at the accessory outlet. DO NOT exceed 500 va rating of the accessory outlet.

# MAINTENANCE

---

**Warning:**  Prior to any maintenance or service on this unit, disconnect the power cord from the power supply. Before reattaching the unit to its power supply, be sure all volatile and flammable cleaners are evaporated and dry.

---

## Cleaning

---

**Note:** The unit chamber should be cleaned and disinfected prior to use.

---

Periodic cleaning is required. To clean the incubator, perform the following steps:

1. Remove all of the interior parts, if assembled.
2. Clean the incubator with a mild soap and water solution, including all corners.  
DO NOT USE spray cleaners that might leak through openings and cracks and get on electrical components, or that may contain solvents that will harm coatings. DO NOT USE chlorine-based bleaches or abrasives, as they will damage the stainless steel interior.
3. Rinse with distilled water and wipe dry with a soft cloth.

## Disinfecting

Disinfect the incubator on a regular basis. To disinfect the incubator, perform the following steps.

1. Remove all of the interior parts, if assembled. The fan blade is replaceable. Stainless steel parts are autoclavable.
2. Disinfect the incubator using a suitable disinfectant. When washing the interior, handle the gasket carefully so as not to impair the positive seal. Decontamination of the shaker mechanism should be done in place if possible. If further disassembly is desired, call customer service.

DO NOT USE spray cleaners that might leak through openings and cracks and get on electrical components, or that may contain solvents that will harm the coatings. DO NOT USE chlorine-based bleaches or abrasives, as they will damage the stainless steel interior. Special care should be taken when cleaning around sensing heads to prevent damage and around the door gasket so as not to impair the positive seal.

## Controls

There is no maintenance required on the main temperature controller, Overtemperature Thermostat or main temperature probe. If the incubator fails to maintain temperature, see TROUBLESHOOTING, before calling customer service.

# TROUBLESHOOTING

Should the unit malfunction, use this section to determine the problem and resolution. Troubleshooting topics include:

- Temperature
- Refrigeration (1575R only)
- Mechanical
- Other

**Warning:** Troubleshooting procedures involve working with high voltages that can cause injury or death.  Troubleshooting should be performed only by trained personnel.

**Table 4. Temperature Troubleshooting**

Problem	Possible Cause	Solution
Temperature too high. The display and reference thermometer do not match	Controller set too high	See Setting the Main Temperature Control.
	Controller failed on	Call customer service.
	Wiring error	Call customer service.
Display reads “HI” or “400”+	Probe is unplugged	Trace wire from display to probe, move wire, and watch display to see intermittent problems.
	Probe is broken	Call customer service.
	Wire to sensor is broken	Call customer service.
Chamber temperature spikes over set point and then settles to set point	N/A	Recalibrate. See Calibrating the Main Temperature Control.
Temperature too low; display and reference thermometer do not match	Overtemperature set too low	Turn thermostat fully clockwise
	Controller set too low	See Setting the Main Temperature Control.
	Unit not recovered from door opening	Wait for display to stop changing.
	Unit not recovered from power failure or being turned off	Incubators will need 24 hours to warm up and stabilize.
	Element failure	See if HEATING light is on; compare current draw to data plate.
	Controller failure	Confirm with front panel lights that controller is calling for heat.
	Thermostat failure	Confirm with front panel lights that



Problem	Possible Cause	Solution
		Overtemperature is operating correctly.
	Wiring problem	Check all functions and compare wiring to the owner's manual, especially around any areas recently worked on.
	Loose connection	Call customer service.
Display reads "LO"	Ambient temperature is lower than range of unit	Compare set points and ambient temperature to rated specifications in UNIT SPECIFICATIONS.
	Sensor is plugged in backwards	Call customer service.
Unit will not heat over a temperature that is below set point	N/A	Confirm that fan is moving and that amperage and voltage match data plate. Check fan motor motion by removing back body panel of the unit.
	N/A	Confirm that set point is set high enough. Turn Overtemperature all the way clockwise and see if HEATING light or OVERTEMP light comes on.
	N/A	Check connections to sensor.
	N/A	Check calibration. Using an independent thermometer, follow instructions in Calibrating the Main Temperature Control.
Unit will not heat up at all	N/A	Verify that controller is asking for heat by looking for HEATING light. If pilot light is not on continuously during initial start up, there is a problem with the controller.
	N/A	Check amperage. Amperage should be virtually at maximum rated (data plate) amperage.
	N/A	Do all controller functions work?
	N/A	Is the Overtemperature Thermostat set high enough? For diagnostics, the Overtemperature Thermostat should be fully clockwise, and the Overtemperature light should not be on.
	N/A	Has the fuse or circuit breaker blown?
Indicated chamber temperature unstable	N/A	±0.1 may be normal.
	N/A	Is the fan working? Remove back panel and verify movement of cooling fan.
	N/A	Is ambient temperature radically changing? The door opening, room airflow from heaters, or air conditioning may be destabilizing temperature. Stabilize ambient conditions.
	Sensor miss-located or damaged or wires may be damaged.	Check mounts for control and Thermostat sensors, then trace wires or tubing between sensors and controls.
	Calibration sensitivity	Call customer service.
	Overtemperature set too low	Ensure that the incubator setting is more than 5 degrees over desired set point. Check if pilot light is on continuously. Turn the controller knob completely clockwise to see if the problem is solved, then follow instructions in Setting the Main

Problem	Possible Cause	Solution
		Temperature Control for correct setting.
	Electrical noise	Remove nearby sources of RFI including motors, arcing relays or radio transmitters.
	Bad connection on temperature sensor or faulty sensor	Check connectors for continuity and mechanical soundness while watching display for erratic behavior. Check sensor and wiring for mechanical damage.
	Bad connections	Check connectors for mechanical soundness and look for corrosion around terminals or signs of arcing or other visible deterioration.
Will not maintain set point	N/A	Assure that set point is at least 5 degrees over ambient.
	N/A	See if ambient is fluctuating. Check for adjacent open doors or HVAC duct openings, stabilize ambient conditions.
Display and reference thermometer do not match	Calibration error	See Calibrating the Main Temperature Control.
	Temperature sensor failure	Evaluate if pilot light is operating correctly.
	Controller failure	Evaluate if pilot light is operating correctly.
	N/A	Allow at least 24 hours to stabilize at set point temperature.
	N/A	Verify that reference thermometer is certified.
Can not adjust set points or calibration	N/A	Turn entire unit off and on to reset.
	N/A	If repeatedly happens, call customer service.
Calibrated at one temperature but not at another	N/A	This can be a normal condition when operating temperature varies widely. For maximum accuracy, calibration should be done at or as close to the set point temperature as possible.

**Note:** N/A is not available.

**Table 5. Refrigeration Troubleshooting (R Suffix Models Only)**

<b>Problem</b>	<b>Possible Cause</b>	<b>Solution</b>
Temperature will not reach set point	N/A	Assure that power is going to heating coils
	N/A	Confirm that controller is calling for heat (check front panel light)
Unit will not cool	Probe is unplugged	<p>If the compressor is running:</p> <ul style="list-style-type: none"> <li>• See if condenser is cold but free of ice</li> <li>• Confirm proper sensor location and operation</li> <li>• Look for leaks in the chamber or around the door gasket</li> <li>• Assure ample room around the unit as described in manual – 5 cm (2 inches) minimum</li> <li>• Adjust calibration on controller</li> <li>• Compare ambient specifications to specifications in the manual</li> <li>• Call customer service</li> </ul>
	N/A	<p>If compressor isn't running:</p> <ul style="list-style-type: none"> <li>• See if refrigeration is running too hot and thermal cutoff activated</li> <li>• Dirty coil or poor circulation</li> <li>• Coil next to heat source</li> <li>• Ambient temperature too high</li> </ul>
Ice build up in chamber	N/A	Look for leak in door gasket
	N/A	Door open too often
	N/A	Open container inside the chamber
	N/A	Check tightness of seal around all chamber wire and plumbing access to outside
Making noise	Steady internal clicking may indicate a broken spring or valve.	Call customer service.

**Note:** N/A is not available.

**Table 6. Mechanical Troubleshooting**

<b>Problem</b>	<b>Possible Cause</b>	<b>Solution</b>
Door not sealing	N/A	Stretch and tuck gasket.
	N/A	Align clamps till they hold gasket tight.
	N/A	Check physical condition of gasket.
	N/A	Tighten door latch until it pulls door tightly closed.
	N/A	Assure that gasket clamps are in original location.
	N/A	Adjust hinge blocks or twist the door
	N/A	Confirm that unit has not been damaged and body is not out of square
Water leaking	N/A	If leaking inside: <ul style="list-style-type: none"> <li>• Dry chamber</li> <li>• Run at temperature with door open.</li> <li>• Check all seams with flashlight including front face</li> </ul>
	N/A	If leaking outside: <ul style="list-style-type: none"> <li>• Dry out and see if leak repeats and find source of leak.</li> <li>• Sources may include: fittings that need tightening, condensation due to missing insulation or a leak developed in compressor compartment</li> </ul>
Shaker motor noise	N/A	Continuous squealing noise of a constant pitch or tone. Changes only in intensity for various rpm settings. Stops when the oscillate switch is turned off. Appears to be coming directly from the motor, not the mechanism or gear box: <ul style="list-style-type: none"> <li>• Make sure the motor cable plugs are properly seated</li> <li>• Replace the speed control</li> </ul>
	N/A	If noise is from the shaft or fan blade, realign the shaft.

**Note:** N/A is not available.

**Table 7. Miscellaneous Troubleshooting**

<b>Problem</b>	<b>Possible Cause</b>	<b>Solution</b>
Controller on at all times and is "locked-up"	N/A	Turn unit off and on to reset.
	N/A	If you cannot change any condition on the front panel, call customer service.
Controller timer resets on its own	N/A	Confirm that power from wall is consistent and within specifications.
	N/A	Call customer service with serial number.
Front panel displays are all off	Unit or wall fuse/circuit breaker is blown.	Check for wire damage.
	N/A	Check wall power source.
	N/A	Compare current draw and compare to specs on data plate.
	N/A	See what other loads are on the wall circuit.
Unit will not turn on	N/A	Check wall power source.
	N/A	Check fuse/circuit breaker on unit or in wall.
	N/A	Check all wiring connections, especially around the on/off switch.
	N/A	See if unit is on (fan or heater), and just controller is off.
Unit is smoking out of the box	N/A	This is not an uncommon occurrence when first operating new units. Put unit under vent and run at full power for one hour. Smoking is normal during first cycle to temperature.
Contamination in chamber	N/A	See Cleaning and Disinfecting sections.
	N/A	Develop and follow standard operating procedure for specific application. Include definition of cleaning technique and maintenance schedule.

**Note:** N/A is not available.

# PARTS LIST

**Table 8. Parts**

Part Description	115 V Part Numbers	220 V Part Numbers	220 V "CE"
Adjustable feet	2700506	2700506	2700506
Control, Mother Board	1750716	1750716	1750716
Counterweight, Single	5460662	5460662	5460662
Display, RPM	1750731	1750731	1750731
Display, Temperature	1750677	1750677	1750677
Door Gasket	3450527	3450527	3450527
Drive Belt, Oscillator	0500512	0500512	0500512
Element	9570703	9570738	9570738
EMI Filter	NA	NA	2800502
Flask Clamps, 1 Liter	9530532	9530532	9530532
Flask Clamps, 125 ml	9530530	9530530	9530530
Flask Clamps, 250 ml	9530531	9530531	9530531
Flask Clamps, 500 ml	9530526	9530526	9530526
Fuse Holder	3300501	3300501	3300501
Fuse, non-refrigerated units	3300513	3300515	3300515
Fuse, refrigerated Units	3300513	3300513	3300513
IEC Inlet	NA	NA	4200505
Knob, Safety Thermostat	4450506	4450506	4450506
Light Ballast	4660501	4660504	4660504
Light Cover	9510502	9510502	9510502
Light Cover Gasket	3450538	3450538	3450538
Light Fluorescent	4650528	4650528	4650528
Light Holder	4660502	4660502	4660502
Motor, Cable	0860503	0860503	0860503
Motor, Circulation	4880527	4880528	4880528
Motor, Oscillator	4880514	4880514	4880514
Pilot Light, Green	200021	200021	200021
Pilot Light, Red	200020	200020	200020

---

<b>Part Description</b>	<b>115 V Part Numbers</b>	<b>220 V Part Numbers</b>	<b>220 V "CE"</b>
Platform (Sample Tray)	5220625	5220625	5220625
Power Cord	1800516	101990	Detachable
Refrigeration Unit, 1575R	7010521	7010543	7010543
Safety Thermostat	10000J	10000J	10000J
Shelf	5100531	5100531	5100531
Shelf Clips	200137	200137	200137
Switch, Door	X1000022	X1000022	X1000022
Switch, Osc, Light, and Accy.	X1000124	X1000124	X1000124
Switch, Power	103351	103351	103351
Transformer "R" Models	NA	100055	100055
Transformer, Speed Control	8350509	8350509	8350509

## UNIT SPECIFICATIONS

**Table 9. Temperature**

Model	Range	Uniformity	Sensitivity	Alarms
1575	Ambient +/-1C° to 37°C Ambient +9F° to 158°F	±.5°C	0.1°C	Visual Safety Lamps
1575R	Ambient -20°C to 70°C (>0°C) Ambient -36°F to 158°F (>32°F)	±.5°C	0.1°C	Visual Safety Lamps

**Table 10. Capacity**

Model	Volume	Standard Shelves	Shelf Dimensions	Max. Number of Shelves
1575	167 L 5.8 CF	2	47 cm x 47 cm 18.5 in. x 18.5 in.	16
1575R	167 L 5.8 CF	2	47 cm x 47 cm 18.5 in. x 18.5 in.	16

**Table 11. Dimensions**

Model	Interior (WxDxH)	Exterior (WxDxH)
1575	48 cm x 51 cm x 66 cm 19 in. x 19.25 in. x 23.5 in.	58 cm x 69 cm x 105 cm 23.5 in. x 28.5 in. x 40.5 in.
1575R	48 cm x 51 cm x 66 cm 19 in. x 19.25 in. x 23.5 in.	58 cm x 69 cm x 105 cm 23.5 in. x 28.5 in. x 40.5 in.



**Table 12. Shaking Mechanism**

Feature	1575	1575R
Motor	brushless DC	brushless DC
Speed, Sample	30 to 400 rpm	30 to 400 rpm
Speed Control	PID Digital ½ in., ¾ in., or 1 in.	PID Digital 1/2 in., ¾ in., or 1 in.
Orbit Diameter	12, 19, or 25 mm	12, 19, or 25 mm
Max Sample Wt.	10 kg (limited by stroke) 22 lbs.	10 kg (limited by stroke) 22 lbs.
Door Switch	Yes	Yes
Platform Dimensions	44 cm x 44 cm 17.3 in. x 17.3 in.	44 cm x 44 cm 17.3 in. x 17.3 in.

**Table 13. Refrigeration**

Model	Compressor Type	Refrigerant
1575	NA	N/A
1575R	1/6 HP	R-134A

**Note:** N/A is not available.

**Table 14. Electrical**

Model	Volts	Hz	Amperage
1575	120V / 240V	50/60 Hz	8.5 / 5.5
1575R	120V / 240V	50/60 Hz	11.5 / 7

# Section 11

## SCHEMATICS

Figure 6. Wire Diagram

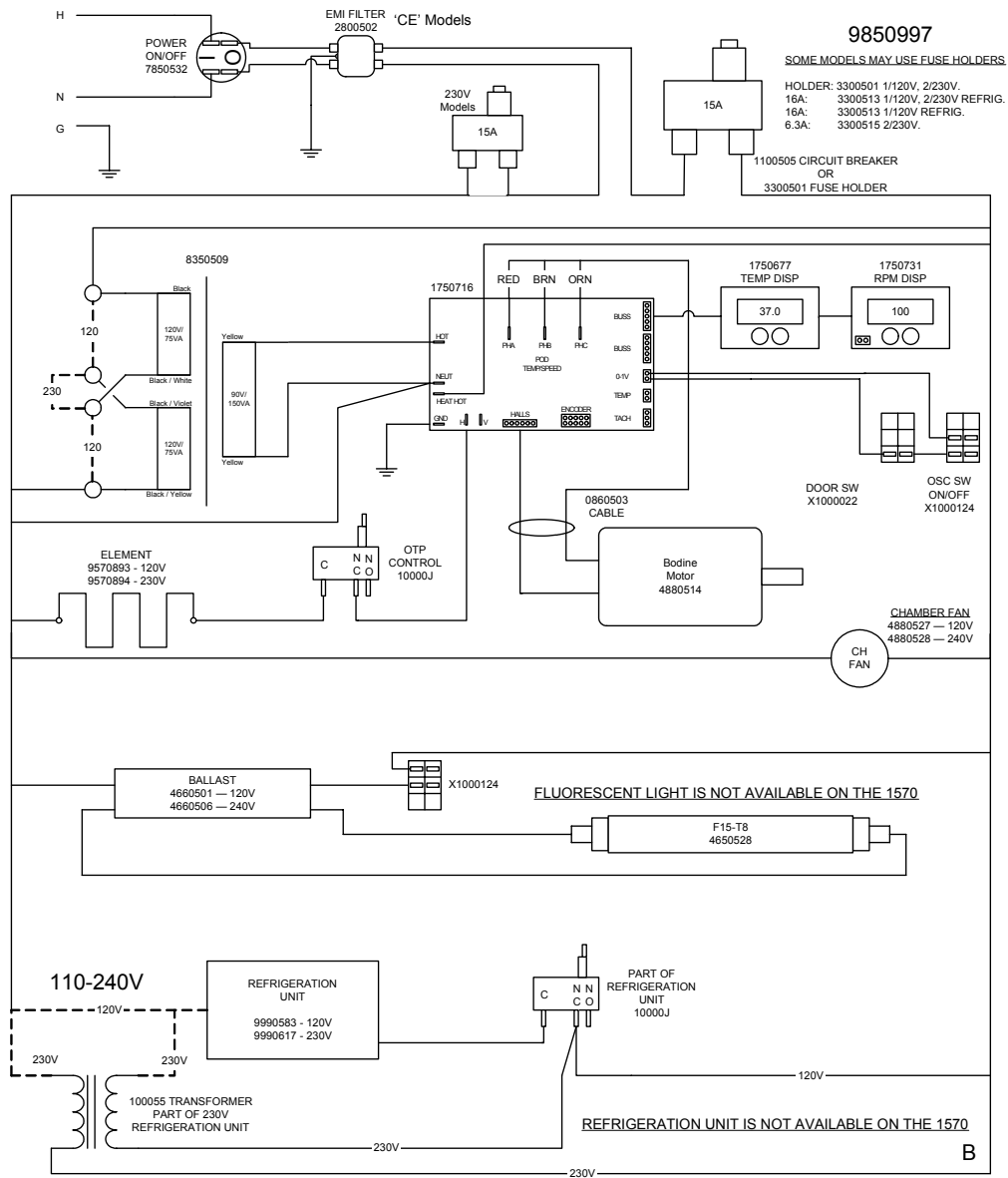

**SHELDON MANUFACTURING, INC.**

**LIMITED WARRANTY**

Sheldon Manufacturing, Inc., (“Manufacturer”) warrants for the original user of this product in the U.S.A. only that this product (parts only if outside of the U.S.A.) will be free from defects in material and workmanship for a period of two years from the date of delivery of this product to the original user (the “Warranty Period”). During the Warranty Period, Manufacturer, at its election and expense, will repair or replace the product or parts that are proven to Manufacturer’s satisfaction to be defective, or, at Manufacturer’s option, refund the price or credit (against the price of future purchases of the product) the price of any products that are proven to Manufacturer’s satisfaction to be defective. This warranty does not include any labor charges if outside of the U.S.A. This warranty does not cover any damage due to accident, misuse, negligence, or abnormal use. Use of Manufacturer’s product in a system that includes components not manufactured by Manufacturer is not covered by this warranty. This warranty is void in the event that repairs are made by anyone other than Manufacturer without prior authorization from Manufacturer. Any alteration or removal of the serial number on Manufacturer’s products will void this warranty. **Under no circumstances will Manufacturer be liable for indirect, incidental, consequential, or special damages.** The terms of this warranty are governed by the laws of the state of Oregon without regards to the principles of conflicts of laws thereof. If any provision of this limited warranty is held to be unenforceable by any court of competent jurisdiction, the remainder of this limited warranty will remain in full force and effect.

**This warranty is in lieu of and excludes all other warranties or obligations, either express or implied. Manufacturer expressly disclaims all implied warranties, including without limitation, the warranties of merchantability and fitness for a particular purpose.**



For fast and efficient support, please have the following information available anytime you request service:

Model \_\_\_\_\_

Serial No. \_\_\_\_\_

Part No. \_\_\_\_\_

## Order From VWR

# Call 800-932-5000

from anywhere in the U.S. and Canada

### Sales & Inventory Locations:

<b>Pacific Northwest Area</b> Anchorage, AK Salt Lake City, UT San Francisco, CA Seattle, WA Tualatin, OR	<b>Midwest Area</b> Chicago, IL Detroit, MI Indianapolis, IN Minneapolis, MN St. Louis, MO	<b>Northeast Area</b> Boston, MA Cincinnati, OH Cleveland, OH Pittsburgh, PA Rochester, NY	<b>Southeast Area</b> Atlanta, GA Oak Ridge, TN
<b>Southwest Area</b> Albuquerque, NM Denver, CO Phoenix, AZ San Diego, CA San Dimas, CA	<b>Gulf Area</b> Austin, TX Dallas, TX Houston, TX Lake Charles, LA	<b>Mid-Atlantic Area</b> Baltimore, MD Branford, CT Bridgeport, NJ S. Plainfield, NJ	<b>VWR Canlab Offices</b> Mississauga, Ontario Ville Mont-Royal, Québec Edmonton, Alberta

### Or Call Direct for Specialized Service Locations:

<b>VWR International</b> 3000 Hadley Rd S. Plainfield, NJ 07080 (908) 757-4045 fax: (908) 757-0313	<b>Switzerland</b> Ruchligstrasse # 20 P.O. Box 464 Dietikon, Switzerland CH-8953 011-41-1-745-1155 fax: 011-41-1-745-1150	<b>VWR Furniture Division</b> P.O. Box 3405 Irving, TX 75015 (972) 714-0336
<b>Puerto Rico</b> Carr. #869 Km. 1.5 M4 Royal Industrial Park Catano, PR 00962 (787) 788-3222 fax: (787) 78804320	<b>VWR Direct</b> 911 Commerce Ct. Buffalo Grove, IL 60089 (800) 444-0880	<b>VWR National Accounts</b> 1310 Goshen Pkwy W. Chester, PA 19380 (610) 431-1700



Visit Our Web Site at

<http://www.vwrsp.com>

# Artisan Technology Group is an independent supplier of quality pre-owned equipment

## Gold-standard solutions

Extend the life of your critical industrial, commercial, and military systems with our superior service and support.

## We buy equipment

Planning to upgrade your current equipment? Have surplus equipment taking up shelf space? We'll give it a new home.

## Learn more!

Visit us at [artisanng.com](http://artisanng.com) for more info on price quotes, drivers, technical specifications, manuals, and documentation.

Artisan Scientific Corporation dba Artisan Technology Group is not an affiliate, representative, or authorized distributor for any manufacturer listed herein.

We're here to make your life easier. How can we help you today?

(217) 352-9330 | [sales@artisanng.com](mailto:sales@artisanng.com) | [artisanng.com](http://artisanng.com)

